

A-CLASS

BoilerMate OV

DESIGN, INSTALLATION AND SERVICING INSTRUCTIONS

PLEASE LEAVE THESE INSTRUCTIONS IN THE POCKET PROVIDED ON
THE BACK OF THE FRONT PANEL

Gas Council Approved Reference Numbers

BMA 125 OV
BMA 145 OV
BMA 185 OV
BMA 210 OV
BMA 225 OV



*The code of practice for the installation,
commissioning & servicing of central heating systems*



**AN OPEN VENTED CENTRAL HEATING
AND MAINS PRESSURE HOT WATER SUPPLY
SYSTEM INCORPORATING
A THERMAL STORE**

**ALL MODELS COMPLY WITH THE
WATER HEATER MANUFACTURERS
SPECIFICATION FOR INTEGRATED THERMAL
STORES**

CONTENTS

ISSUE 3: 09/05

Section	Page
1.0 DESIGN	
1.1 Introduction	3
1.2 Technical Data	5
1.3 System Details	11
2.0 INSTALLATION	
2.1 Site Requirements	19
2.2 Installation	20
2.3 Commissioning	30
3.0 SERVICING	
3.1 Annual Servicing	34
3.2 Changing Components	34
3.3 Short Parts List	35
3.4 Fault Finding	36
Appendix A	37
Appendix B	38
Appendix C	41
Appendix D	42
Terms & Conditions	43



*The code of practice for the installation,
commissioning & servicing of central heating systems*

As part of the industry wide "Benchmark" Initiative all Gledhill BoilerMates now include a Benchmark Installation, Commissioning and Service Record Log Book. Please read carefully and complete all sections relevant to the appliance installation. The details of the Log Book will be required in the event of any warranty work being required. There is also a section to be completed after each regular service visit. **The completed Log Book and these instructions should be left in the pocket provided on the back of the front panel.**

The Gledhill BoilerMate range is a WBS listed product and complies with the WMA Specification for integrated thermal storage products. The principle was developed in conjunction with British Gas. This product is manufactured under an ISO 9001:2000 Quality System audited by BSI.

Patents Pending

The Gledhill Group's first priority is to give a high quality service to our customers.

Quality is built into every Gledhill product and we hope you get satisfactory service from Gledhill.

If not please let us know.

1.0 DESIGN

1.1 INTRODUCTION

These instructions should be read in conjunction with the Installation and Servicing Instructions issued by the manufacturers of the heat source e.g. the boiler used.

Any water distribution and central heating installation must comply with the relevant recommendations of the current version of the Regulations and British Standards listed below:-

Gas Safety Regulations
Building Regulations
I.E.E. Requirements for Electrical Installations
Water Regulations

British Standards

BS6798, BS5449, BS5546, BS5440:1, BS5440:2, CP331:3, BS6700, BS5258, BS7593 and BS7671.

A competent person as stated in the Gas Safety Regulations must install the BoilerMate heating system. The manufacturer's notes must not be taken as overriding statutory obligations.

The BoilerMate A-Class is only suitable for use with an open vented central heating system.

The BoilerMate A-Class is not covered by section G3 of the current Building Regulations and is therefore not notifiable to Building Control.

The information in this manual is provided to assist generally in the selection of equipment. The responsibility for the selection and specification of the equipment must however remain that of the customer and any Designers or Consultants concerned with the design and installation.

Please Note: We do not therefore accept any responsibility for matters of design, selection or specification or for the effectiveness of an installation containing one of our products unless we have been specifically requested to do so.

All goods are sold subject to our Conditions of Sale, which are set out at the rear of this manual.

In the interest of continuously improving the BoilerMate range, Gledhill Water Storage Ltd reserve the right to modify the product without notice, and in these circumstances this document, which is accurate at the time of printing, should be disregarded. It will however be updated as soon as possible after the change has occurred.

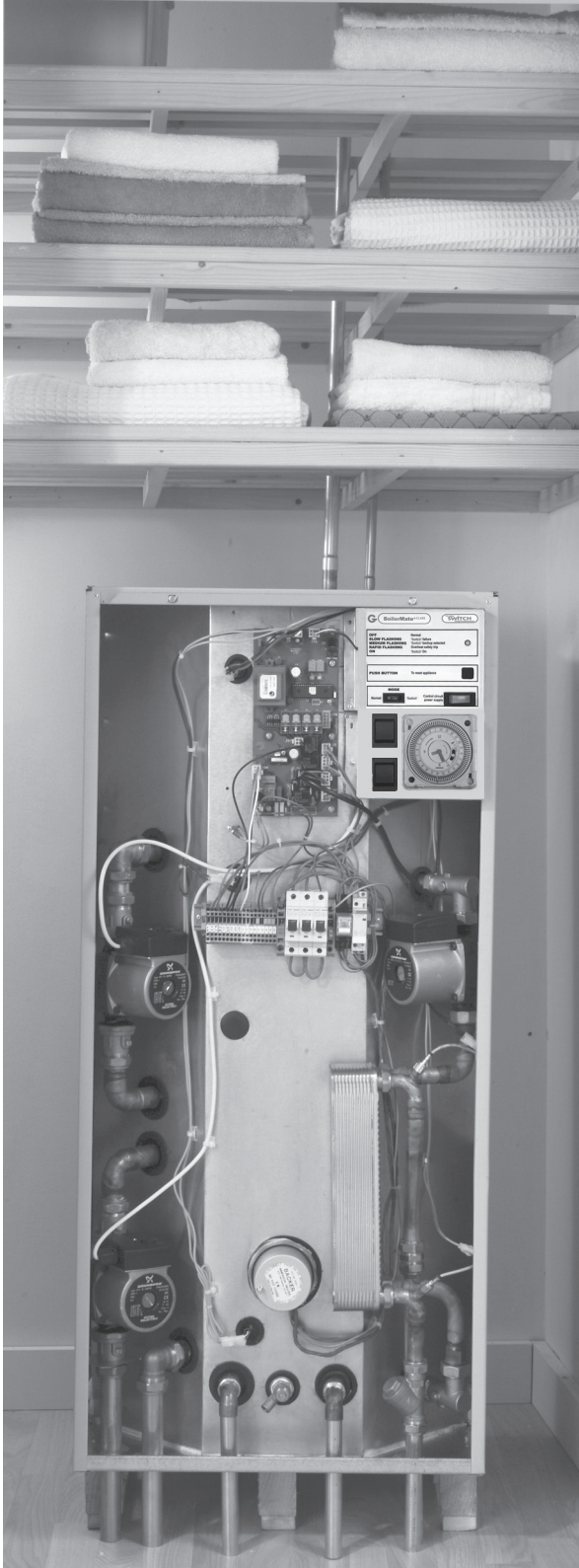

1.0 DESIGN

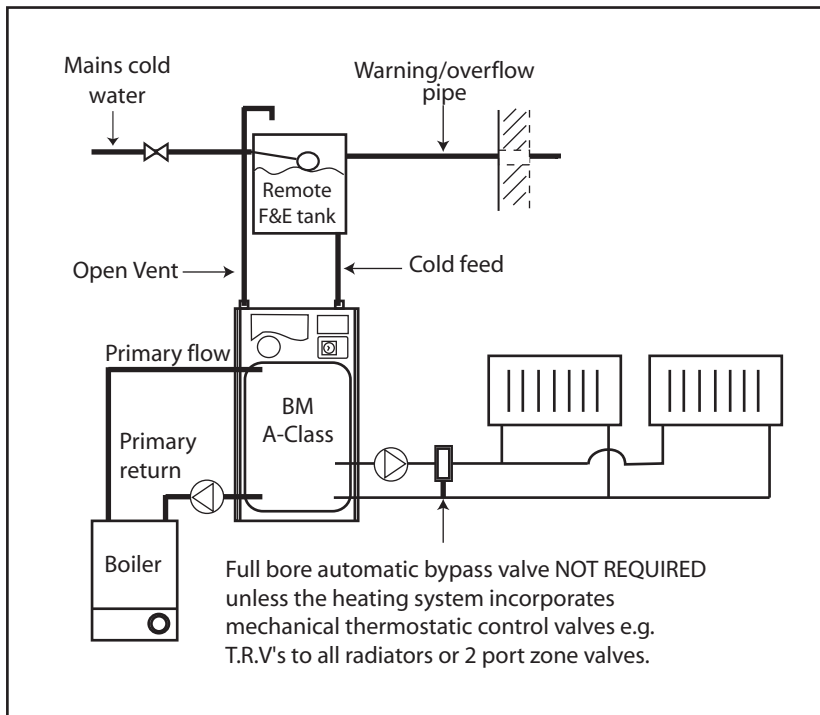

The A.C.B. also incorporates the facility to operate the heating pump for a few seconds every few days when the heating is not being used (to reduce the likelihood of the pumps sticking) as well as providing a boiler pump overrun facility.

Any automatic boiler designed to operate on an 82°C flow and a 71°C return up to a maximum of 35kW can be linked to any suitable model of BoilerMate A-Class and the deciding factor is the space heating and the hot water requirements of a dwelling. See Section 1.2 Technical Data for further details.

The BoilerMate A-Class OV is supplied complete with 'Switch' which will provide a 6kW electrical emergency backup in case of failure of the main heat source. See section 1.3 System Details for further information.

Gledhill are part of the 'Benchmark' scheme and a separate commissioning/service log book is included with the product.

A 15mm connection is provided on the primary return on all units to allow for the provision of a pumped summer use towel rail circuit if required (see page 16 for further details)

1.1 INTRODUCTION

Description

The BoilerMate A-Class OV shown schematically above is designed to provide improved space heating and mains pressure hot water when coupled to any remotely sited condensing or non condensing boiler.

The principle of a BoilerMate A-Class is to separate the heat generator e.g. a boiler from heat emitters (radiators) by a thermal store, which evens out the fluctuating demands for heating and hot water.

An important feature of this concept is that hot water can be supplied directly from the mains at conventional flow rates without the need for temperature and pressure relief safety valves or expansion vessels. This is achieved by passing the mains water through a plate heat exchanger. The outlet temperature of the domestic hot water is maintained by a printed circuit board (A.C.B.), which controls the speed of the pump circulating the primary water from the store through the plate heat exchanger.

To comply with the Benchmark Guidance Note for Water Treatment in heating and hot water systems the installer should check the hardness levels of the water supply and if necessary fit an in-line scale inhibitor/reducer to provide protection to the whole of the domestic water system.

We recommend the use of the optional scale inhibitor to help protect the appliance itself if the hardness level is above 280 ppm (mg/l).

If scale should ever become a problem the plate heat exchanger is easily isolated and quickly replaced with a service exchange unit which can be obtained at a nominal cost from Gledhill.

Note

The BoilerMate OV is a SYSTEM appliance and only requires a basic boiler. If a system boiler is chosen this will present wiring/operational difficulties as well as incurring extra costs.

1.0 DESIGN

1.2 TECHNICAL DATA

Model	BMA 125 OV	BMA 145 OV	BMA 185 OV	BMA 210 OV	BMA 225 OV
Weight (empty)	45	47	50	51	56
Weight (full)	177	187	197	215	244
DHW Pump	Grundfos UPR 15/50	Grundfos UPR 15/50	Grundfos UPR 15/50	Grundfos UPR 15/50	Grundfos UPR 15/50
Heating Pump	Grundfos UPS 15/50	Grundfos UPS 15/50	Grundfos UPS 15/50	Grundfos UPS 15/60	Grundfos UPS 15/60
Boiler Pump	Grundfos UPS 15/50	Grundfos UPS 15/50	Grundfos UPS 15/50	Grundfos UPS 15/60	Grundfos UPS 15/60
Primary/heating pipe connections	22mm	22mm	22mm	28mm	28mm
MCW & DHW pipe connections	22mm	22mm	22mm	22mm	22mm
Cold feed/expansion connection	22mm	22mm	22mm	22mm	22mm
Safety open vent connection	22mm	22mm	22mm	22mm	22mm
Primary return (for summer use bathroom towel rail)	15mm	15mm	15mm	15mm	15mm
Maximum summer towel rail load	0.15kW	0.75kW	1.00kW	1.25 kW	1.5 kW
Drain connection	R ½"	R ½"	R ½"	R ½"	R ½"
Maximum Head	10 meters	10 meters	10 meters	10 meters	10 meters
Hot water flow rate (l/m) up to	35	35	35	35	35
Max heating system size	12 kW	17 kW	20 kW	25 kW	30 kW
'Switch'	6 kW	6 kW	6 kW	6 kW	6 kW
Typical Dwelling Types					
Bedrooms	1-3	2-3	2-4	3-5	4-6
Bathrooms	1	1	2	1 2	1 3 4
En-suite shower	1	2	1	4 2	4 2 0

Notes:-

1. The BoilerMate 225 appliance is suitable for use in large properties because it produces the same 'peak hour output' as a typical 350-400 litre unvented cylinder. For properties requiring the BMA 225 the incoming main should be a minimum of 32mm MDPE with a pressure of not less than 2 bar dynamic and an adequate flow in line with the pipe sizing calculations. In many cases, properties of this size will benefit from having 2 smaller sized appliances located adjacent to the areas of peak hot water use. This will allow 2 heating zones to be provided and remove the need to provide trace heating on the hot water system.
2. A plastic feed and expansion cistern will be supplied separately including ballvalve, float and overflow fitting.
3. The flow rates are based on a 35°C temperature rise and assume normal pressure and adequate flow to the appliance. The actual flow rate from the appliance is automatically regulated to a maximum of 28 litres/min.
4. Unit is supplied on a 100mm high installation base.
5. The domestic hot water outlet temperature is automatically regulated to approximately 52°C at the bath flow rate of 18 litres/min recommended by BS 6700. The temperature is not user adjustable.

1.0 DESIGN

1.2 TECHNICAL DATA

Standard Equipment

The standard configuration of the BoilerMate A-Class OV is shown opposite. The Appliance Control Board (A.C.B.), mounted inside the appliance, controls the operation of the complete system. The A.C.B. is pre-wired to a terminal strip where all electrical connections terminate. It is supplied with the following factory fitted equipment:-

1. Boiler pump
2. Domestic hot water primary (plate heat exchanger) pump - modulating
3. Space heating pump
4. Appliance control board (A.C.B.)
5. Electro-mechanical clock and hot water and space heating control rockers.
6. Plate heat exchanger
7. DHWS temperature sensor
8. Cold water inlet sensor
9. Store temperature sensors
10. Overheat sensor
11. Y type strainer/flow regulator
12. A feed and expansion cistern complete with ballvalve, overflow fitting and cold feed/open vent pipework assembly is supplied separately.
13. 'Switch' elements (2 x 3 kW)

Optional Equipment

- * A seven day digital clock/programmer to control the space heating (in conjunction with a room thermostat)
- * A kit to site the clock/programmer remotely.
- * A no clock/multi-zone option.
- * Hot and cold water manifolds for use with plastic pipework.
- * Modulating type (UPR) pump for the boiler/space heating circuits.
- * Scale inhibitor for water services with hardness levels above 280ppm (mg/l)

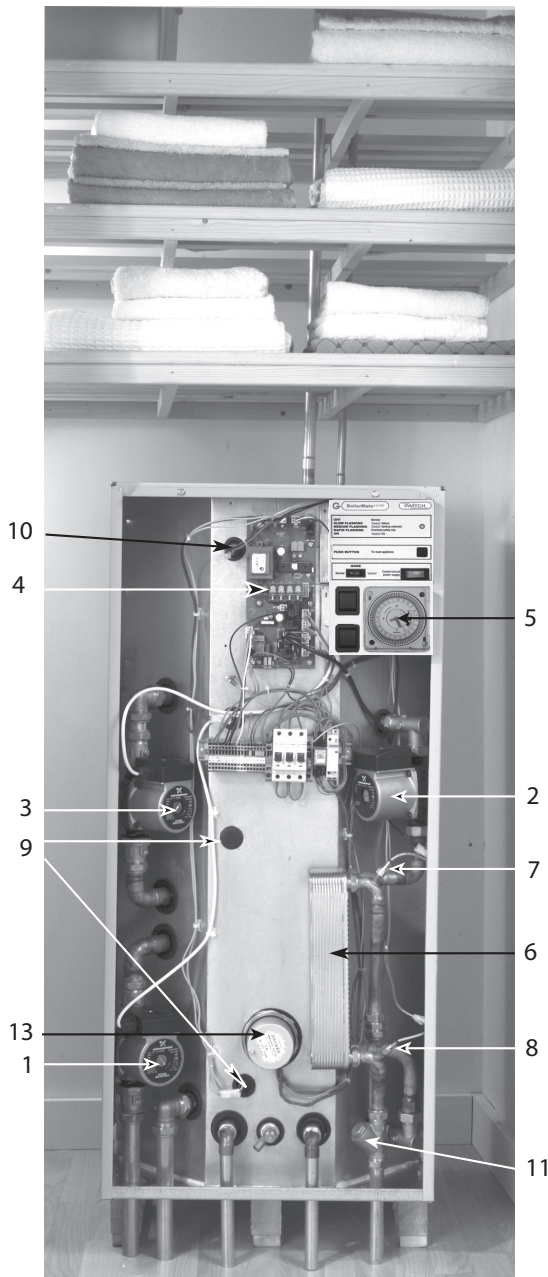

Digital clock programmer

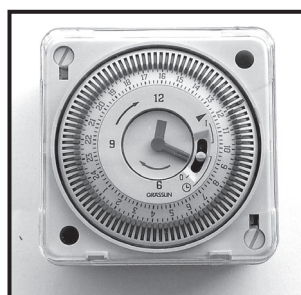

Electro-mechanical clock programmer

1.0 DESIGN

1.2 TECHNICAL DATA

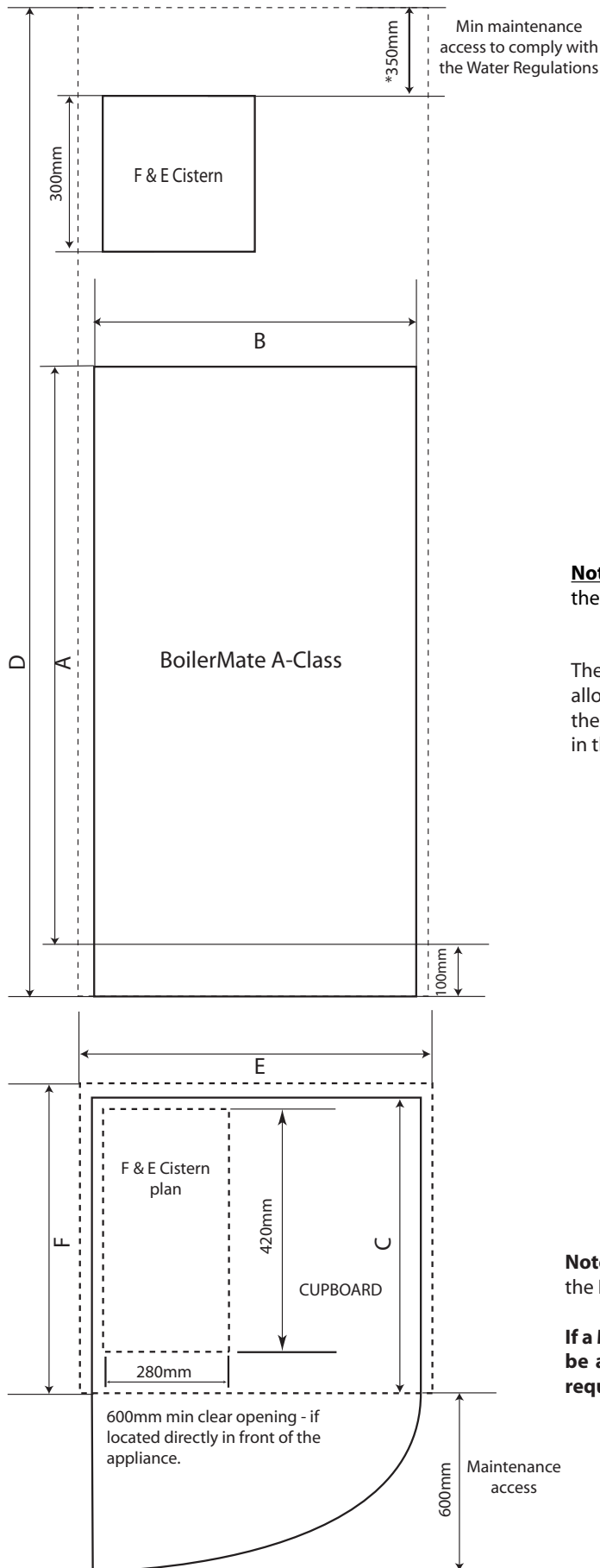

APPLIANCE DIMENSIONS			
MODEL	Height	Width	Depth
	A	B	C
BMA 125 OV	960mm	530mm	595mm
BMA 145 OV	1000mm	530mm	595mm
BMA 185 OV	1040mm	530mm	595mm
BMA 210 OV	1145mm	530mm	595mm
BMA 225 OV	1300mm	530mm	595mm

Note: The Appliance dimensions above do not allow for the 100mm high installation base

The following table of minimum cupboard dimensions only allow the minimum space required for the appliance (including the F & E cistern) and any extra space required for shelving etc in the case of airing cupboards etc must be added.

MINIMUM CUPBOARD DIMENSIONS			
MODEL	Height	Width	Depth
	D	E	F
BMA 125 OV	1710mm	630mm	600mm
BMA 145 OV	1750mm	630mm	600mm
BMA 185 OV	1790mm	630mm	600mm
BMA 210 OV	1895mm	630mm	600mm
BMA 225 OV	2050mm	630mm	600mm

Note: The above dimensions are based on the Appliance and the F & E cistern being in the same cupboard.

If a Multi-Zone appliance is used an additional 150mm must be added to the above heights to accommodate the space required for the zone equipment.

1.0 DESIGN

1.2 TECHNICAL DATA

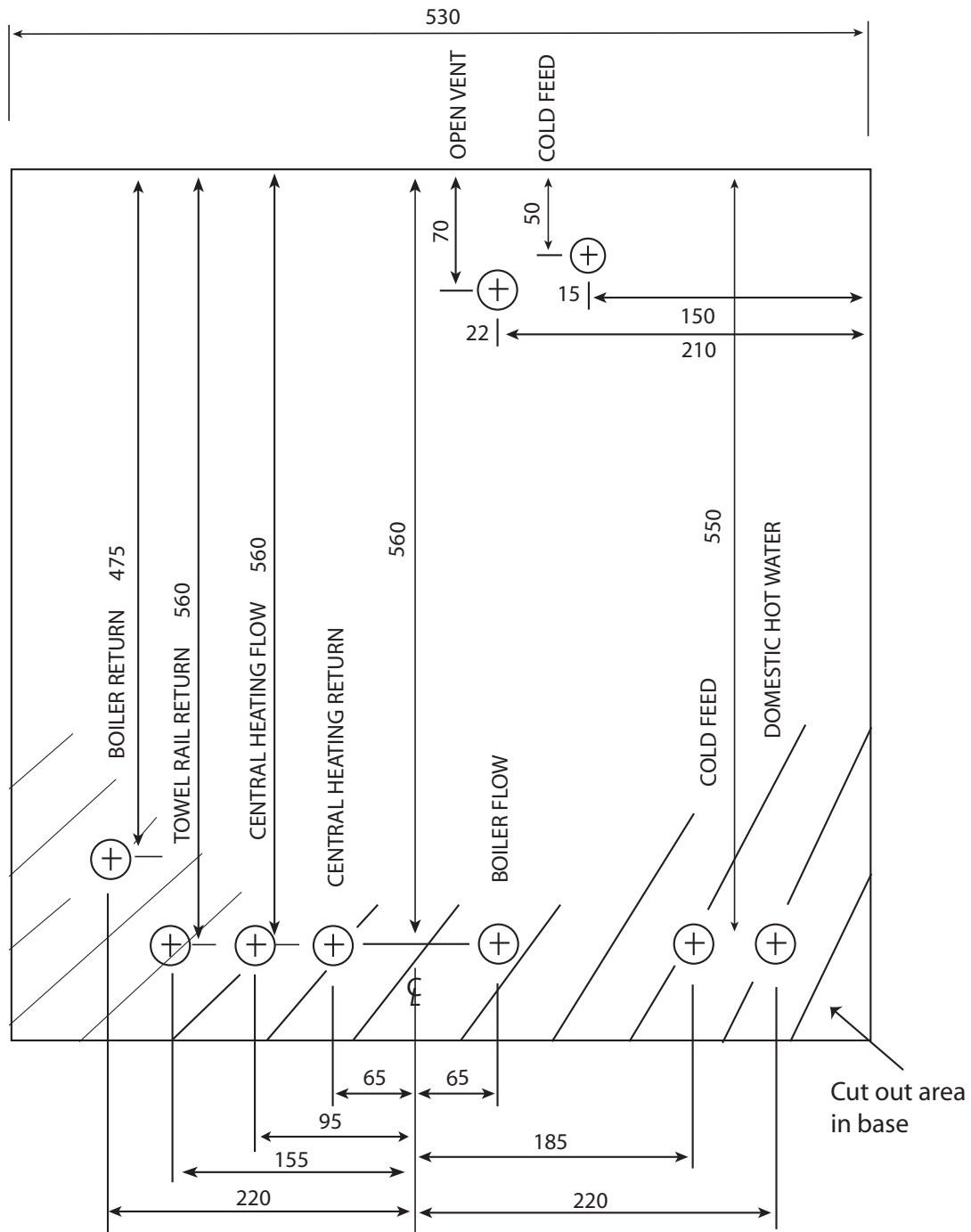

All dimensions in mm - to centre line of pipework

The BoilerMate A-Class units are supplied on an installation base to allow the pipe runs to connect to the appliance from any direction. It is easier if all pipes protrude vertically in the cut out area shown. Compression or push fit connections can be used. All pipe positions are approximate and subject to a tolerance of ± 20 mm in any direction. A 15mm cold water supply and a 22mm warning/overflow pipe will also be required for the separate feed and expansion tank.

1.0 DESIGN

1.2 TECHNICAL DATA

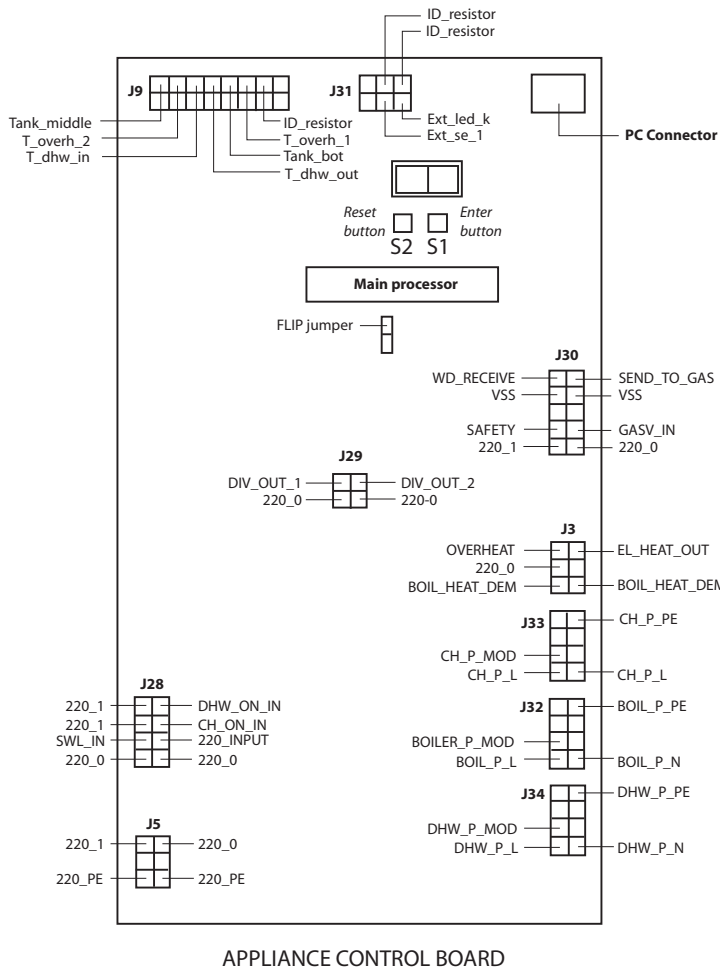

APPLIANCE CONTROL BOARD

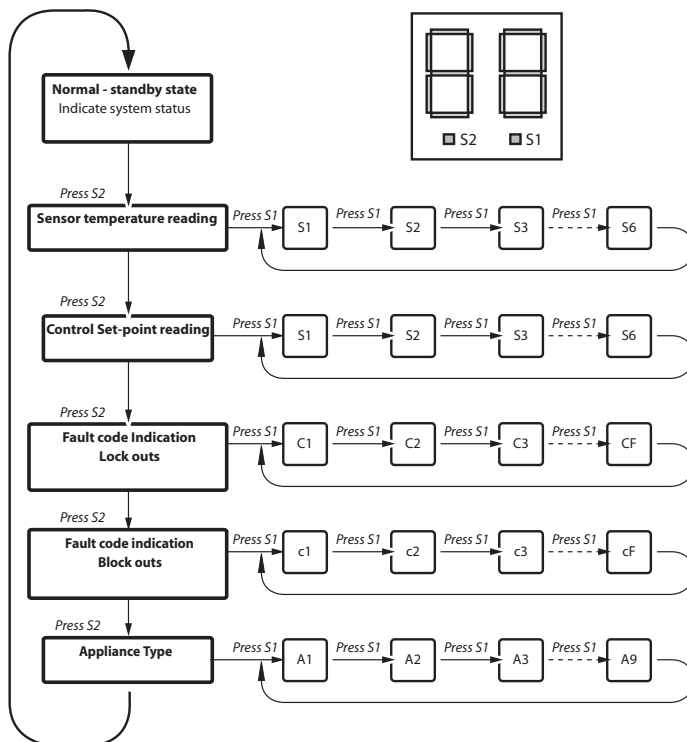

2 Digit ACB Board Display Flow Chart

Appliance Control Board

The appliance control board (shown opposite) has a 2 digit display and 2 push buttons which are used to check the status of the appliance, check and set its identity and interrogate it for the current faults and the fault history.

The 2 digit display is controlled by 2 buttons S1 and S2. The flow chart of display modes is shown below. Generally, each press of button S2 cycles the display from top to bottom and each press of button S1 cycles the display functions from left to right.

The button S2 is also used to reset the appliance i.e. clear the lockout errors and reset the appliance. (Note: Appliance resetting can also be carried out using the push button on the front panel)

Display in Normal (Standby) Mode

In the standard/normal mode the 2 digit display indicates the status of the appliance inputs and outputs by switching on the appropriate segments of the display - see page 29 for details.

Appliance Type Selection

The BoilerMate is fitted with an identity (ID) resistor which is read by the controller for comparison with the appliance type (code) set on the controller. The two must match for the controller/appliance to function. Therefore if either the appliance code setting or the ID resistor is wrong, the appliance will shut down safely and flag the error code until the fault is rectified. The controller codes and the ID resistor values for the BoilerMate are 01 and 1K5 respectively. The procedure for checking and setting the appliance code on the controller is described below.

- The appliance selection menu (A0 ... A9) on the controller is hidden. It is only possible to get to the appliance selection using the reset button (Left hand, S2) on the main board.

- When going from the show 'locking error' to show 'blocking error' menu (see opposite), do not release the button but hold it for 10 seconds. The display will change from 'c' to 'A'. At this stage the push button (S2) can be released.

- The appliance type can now be selected by using right hand push button, S1, e.g. for this appliance A01.

Press the reset button, S2, to accept the setting.

If the selected appliance code does not match with the ID resistor fitted to the appliance, then, an error '33' will be displayed.

1.0 DESIGN

1.2 TECHNICAL DATA

Sensor Temperature Readings

Details of the various sensors S1-S6 used in the BoilerMate A-Class are shown opposite. The sensor reference i.e. S1 and the actual temperature at that sensor flash alternately on the display when selected.

Sensors used in BoilerMate A-Class			
Sensor	Sensor	Connector J9 pins	Location
S1	T Overheat 1	6 & 14	Top of store in dry pocket (S1 & S2 are in single housing)
S2	T Overheat 2	2 & 10	
S3	T DHW in	3 & 11	In cold water inlet pipe (Wet i.e. direct)
S4	T DHW out	4 & 12	In hot water outlet pipe (Wet i.e. direct)
S5	T Tank bottom	5 & 13	Bottom of store in dry pocket for store charging
S6	T Tank middle	1 & 9	Middle of store in dry pocket for store charging

Sensor Control Set Points		
Display	Sensor	Temp
S1	Middle store sensor on	68
S2	Middle store sensor off	77
S3	DHW in	35
S4	DHW out	55
S5	Bottom store sensor on	60
S6	Bottom store sensor off	70

Control Set Points

The sensor control set points are shown opposite. PLEASE NOTE THAT THE DISPLAY S1 - S6 IS NOT THE SAME AS THE SENSOR REFERENCE.

Common Fault Codes			
Code		Code	
10	Overheat error	45	S1 overheat 1 shorted
30	Phase error	48	I.D.resistor shorted
33	Appliance selection	49	S4 sensor shorted
37	S1 overheat 1 open	50	S5 sensor shorted
40	I.D.resistor open	51	S6 sensor shorted
41	S4 sensor open	52	S2 overheat 2 shorted
42	S5 sensor open		
43	S6 sensor open		
44	S2 overheat 2 open		
Any other code displayed should be checked against the full chart			

Fault Codes

Fault code locations are numbered C0 - CF and c0 - cF.
 CO/cO locations hold the latest fault recorded. A code of FF indicates that the fault location is empty.
 If a sensor is faulty instead of a temperature it will show E1 if open circuit and E2 if short circuit.

1.3 SYSTEM DETAILS

Hot and Cold Water System

General

A schematic layout of the hot and cold water services in a typical small dwelling is shown below. BoilerMate A-Class will operate at mains pressures as low as 1 bar and as high as 5 bar although the recommended range is 2-3 bar. These pressures are the minimum dynamic pressures at the cold connection to the BoilerMate A-Class at the time of the maximum calculated simultaneous demand. If the manifolds (available as an optional extra) are being used the inlet pressure to the manifold must be a minimum of 2 bar. Particular consideration should also be given to available pressures in the case of 3 storey properties. It is also important to check that all other equipment and components in the hot and cold water system are capable of accepting the mains pressure available to the property. If the mains pressure can rise above 5 bar or the maximum working pressure of any item of equipment or component to be fitted in the system a pressure limiting (reducing) valve set to 3 bar will be required.

If you encounter a situation where the water pressure is adequate but flow rates are poor please contact our technical helpline for details of an effective solution.

Note: Each BoilerMate A-Class is fitted with a strainer and flow regulator on the cold mains supply connection. If the supply pressure is less than 2 bar or if the manifolds (available as an optional extra) are being used or if all taps are provided with flow regulators the flow regulator on the cold inlet should be removed.

No check valve or similar device should be fitted on the cold water supply branch to the BoilerMate A-Class.

To comply with the Benchmark Guidance Note for Water Treatment in Heating and Hot Water Systems the installer should check the hardness level of the water supply and if necessary fit an in-line scale inhibitor/reducer to provide protection to the whole of the domestic water system. See Appendix C for a copy of the relevant part of the Benchmark Guidance Note.

The standard appliance is suitable for hardness levels up to 280 ppm without the use of a scale inhibitor. For hardness levels above 280ppm (mg/l) we would recommend that the appliance is ordered with the optional factory fitted scale inhibitor.

If scale should ever become a problem the plate heat exchanger is easily isolated and quickly replaced with a service exchange unit which can be obtained at a nominal cost from Gledhill.

The hot water flow rate from the BoilerMate A-Class is directly related to the adequacy of the cold water supply to the dwelling. This must be capable of providing for those services, which could be required to be supplied simultaneously, and this maximum demand should be calculated using procedures defined in BS 6700.

If a water meter is fitted in the service pipe, it should have a nominal rating to match the maximum hot and cold water peak demands calculated in accordance with BS 6700. This could be up to 80ltr/min in some properties.

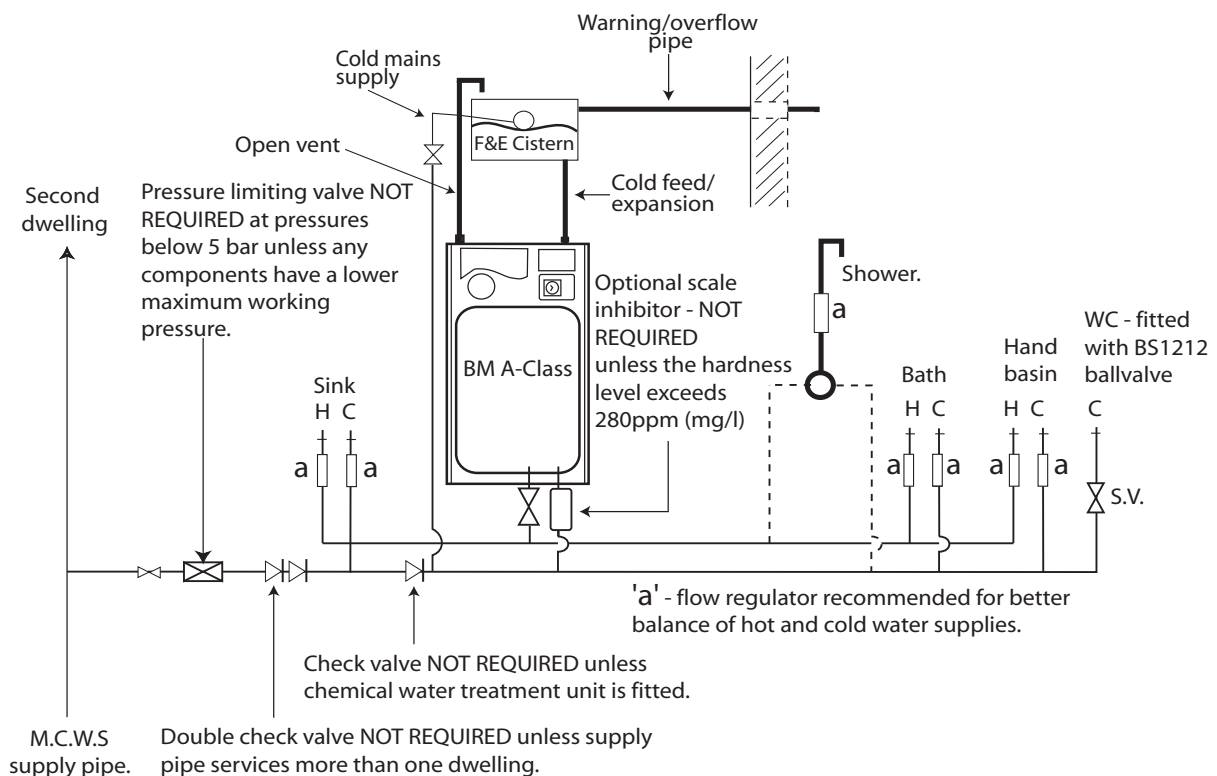

Typical hot and cold water distribution

1.3 SYSTEM DETAILS

Hot and Cold Water System

Pipe Sizing / Materials

To achieve even distribution of the available supply of hot and cold water, it is important in any mains pressure system, that the piping in a dwelling should be sized in accordance with BS 6700. This is particularly important in a large property with more than one bathroom.

However, the following rule of thumb guide lines should be adequate for most smaller property types as long as water pressures are within the recommended range of 2-3 bar.

1. A 15mm copper or equivalent external service may be sufficient for a small 1 bathroom dwelling (depending upon the flow rate available), but the minimum recommended size for new dwellings is 22mm (25mm MDPE). For the BMA 225 model we recommend a 28mm (32mm MDPE) supply pipe.
2. The internal cold feed from the main incoming stop tap to the BoilerMate should be run in 22mm pipe. The cold main and hot draw-off should also be run in 22mm as far as the branch to the bath tap.
3. The final branches to the hand basins and sinks should be in 10mm and to the baths and showers in 15mm. (1 metre minimum)
4. If an external hose tap is provided this should be branched in 15mm pipework from the cold pipework as near to the incoming mains as possible.
5. **We would recommend that best results for a balanced system are achieved by fitting appropriate flow regulators to each hot and cold outlet. This is particularly relevant where the water pressures are above the recommended water pressure range of 2-3 bar, or the dwelling is 3 storey. Details of suitable flow regulators are provided in Appendix A.**

Note: If manifolds (available as an optional extra) are being used suitable flow regulators are automatically provided in the manifold and do not need to be provided at each outlet - See Appendix B for further details.

All the recommendations with regard to pipework systems in this manual are generally based on the use of BS/EN Standard copper pipework and fittings.

However, we are happy that plastic pipework systems can be used in place of copper internally as long as the chosen system is recommended for use on domestic hot and cold water systems by the manufacturer and is installed fully in accordance with their recommendations.

It is also essential that if an alternative pipework material/system is chosen the manufacturer confirms that the design criteria of the new system is at least equivalent to the use of BS/EN Standard copper pipework and fittings.

Taps/Shower Fittings

Aerated taps are recommended to prevent splashing.

Any type of shower mixing valve can be used as long as both the hot and cold supplies are mains fed. However, all mains pressure systems are subject to dynamic changes particularly when other hot and cold taps/showers are opened and closed, which will cause changes in the water temperature at mixed water outlets such as showers. For this reason and because these are now no more expensive than a manual shower we strongly recommend the use of thermostatic showers with this appliance. These must be used in 3 storey properties where the impact on pressure/temperature of opening another tap in the system is greater than normal.

The shower head provided must also be suitable for mains pressure supplies.

However, if it is proposed to use a 'whole body' or similar shower with a number of high flow/pressure outlets please discuss with the Gledhill technical department.

The hot water supply to a shower-mixing valve should be fed wherever practical directly from the BoilerMate A-Class or be the first draw-off point on the hot circuit. The cold supply to a shower-mixing valve should wherever practical be fed directly from the rising mains via an independent branch. The shower must incorporate or be fitted with the necessary check valves to provide back-syphonage protection in accordance with the Water Regulations.

The supply of hot and cold mains water directly to a bidet is permitted provided that it is of the over-rim flushing type and that a type 'A' air gap is incorporated.

Hot and Cold Water System.

If the length of the hot water draw off pipework is excessive the delivery time may be unacceptable before hot water is available at the tap, you may wish to consider using trace heating to the hot water pipework such as the Raychem HWAT system. Please consult Gledhill Technical Department for further details.

It is important that the cold water pipework is adequately separated/protected from any heating/hot water pipework to ensure that the water remains cold and of drinking water quality.

1.0 DESIGN

1.3 SYSTEM DETAILS

Heating System

General

A schematic layout of the heating system in a typical small dwelling is shown opposite.

The flow and return from the boiler must always run directly to the BoilerMate A-Class and the flow should rise continuously to facilitate venting. The heating circuit is taken from the BoilerMate A-Class and is piped in the conventional manner.

The BoilerMate A-Class is only suitable for an open vented system.

The F & E cistern can be fitted remotely up to 10m above the base of the BoilerMate A-Class i.e. the maximum static pressure in the store must not exceed 1 bar.

If any radiators are located above the level of the BoilerMate A-Class the system should be designed so that gravity circulation does not occur when the heating pump is not running. To be certain of preventing this it is recommended that a check valve, or valves, are fitted on the vertical flow pipes.

The water level in the F & E cistern should be at least 250mm above the highest point on the system including the radiators and must be high enough to provide the minimum head required by the boiler being used.

The boiler manufacturer's instructions with regard to minimum head must always be followed. This is particularly important in situations where the headroom is restricted (e.g. in a flat).

Range rated boilers can be used but should always be set at the **highest** output. The system efficiency will not be impaired while the recovery rate will be improved.

It is not necessary to provide a boiler bypass on the primary circuit (i.e. between the boiler and the thermal store.)

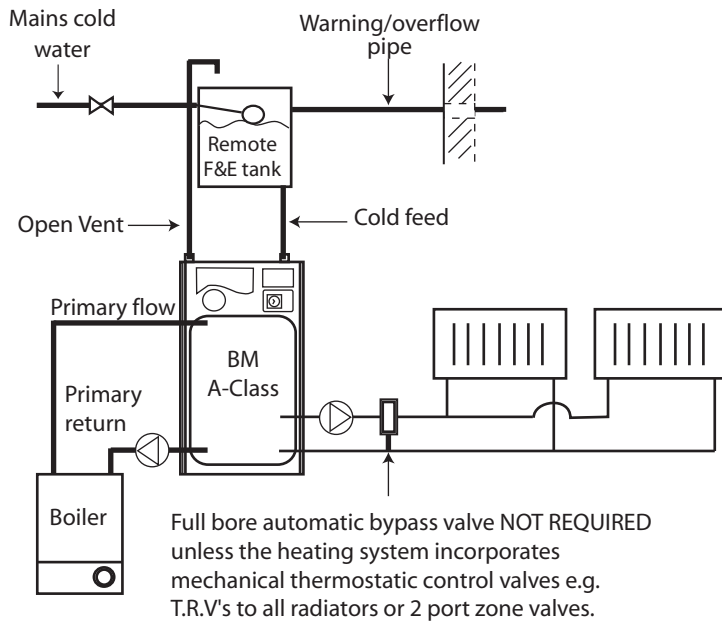

1.0 DESIGN

1.3 SYSTEM DETAILS

Heating System

Pipe Sizing/Materials

The primary pipework connecting the boiler and the thermal store should be sized to achieve a maximum of 8°C rise across the boiler or the maximum temperature rise specified by the boiler manufacturer, whichever is smaller, but in any instance it should not be less than 22mm copper tube.

Note: There should be no valves in the pipework connecting the boiler to the BoilerMate A-Class.

The heating circuit operates on the normal primary boiler temperatures i.e. 82°C flow and 71°C return. Therefore any traditional hot water radiators or convectors can be used with this system and no special over-sizing of the heat emitters is necessary.

All the recommendations with regard to pipework systems in this manual are generally based on the use of BS/EN Standard copper pipework and fittings.

However, we are happy that plastic pipework systems can be used in place of copper internally as long as the chosen system is recommended for use on domestic heating systems by the manufacturer and is installed fully in accordance with their recommendations. We always recommend the use of barrier pipe for these systems.

It is also essential that if an alternative pipework material/system is chosen the manufacturer confirms that the design criteria of the new system is at least equivalent to the use of BS/EN Standard copper pipework and fittings.

Boiler Size

It is only necessary to calculate the heating requirements in accordance with BS 5449. The allowances shown below should be added for domestic hot water. The control system automatically gives priority to hot water when necessary.

Allowance for domestic hot water	
Model	(kw)
BM125	3
BM145	3
BM185	4
BM210	5
BM225	6

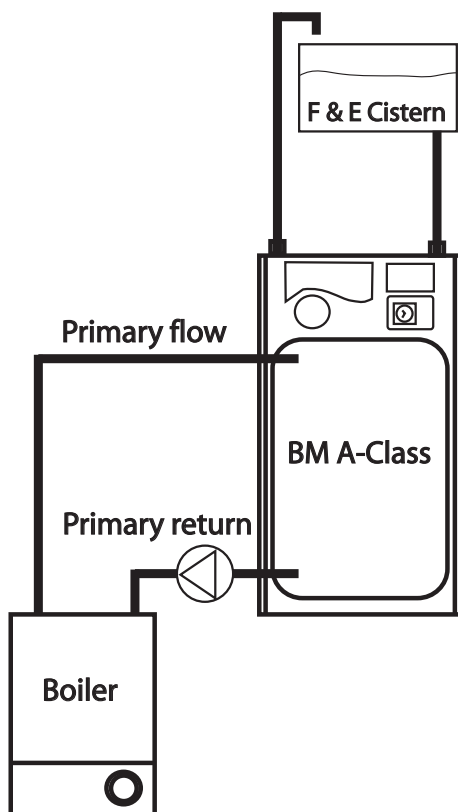

Boiler Sited Below BoilerMate A-Class

Any temperature controlled boiler can be used when the flow pipe from the boiler to the BoilerMate A-Class rises continuously. No valve shall be fitted in the primary flow or open vent.

1.0 DESIGN

1.3 SYSTEM DETAILS

Heating System

Boiler sited above the BoilerMate

A.V. Automatic air vent
C.V. Gravity check valve

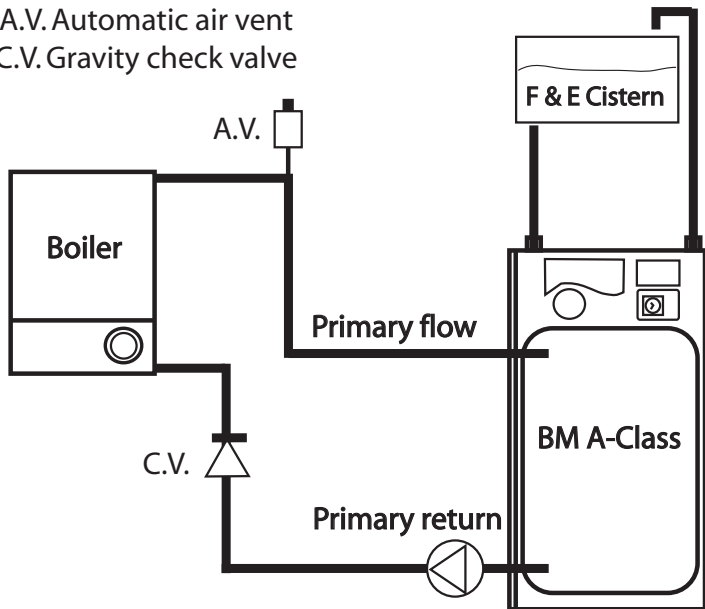

Any boiler used must be fitted with an overheat thermostat i.e. it must be suitable for use in a sealed system.

The F & E cistern must be fitted at a height which will provide the minimum head required for the boiler and must be at least 250mm above the highest point of the system.

The height of the water level in the F & E cistern from the base of the store should be no greater than 10m.

A gravity check valve should be fitted in the boiler return pipework to prevent gravity circulation between the BoilerMate A-Class and the boiler during dormant periods.

An automatic air vent will be required on the flow adjacent to the boiler and depending upon the pipe layout a manual air vent may also be required on the return adjacent to the boiler - see boiler installation instructions.

A.V. Automatic air vent

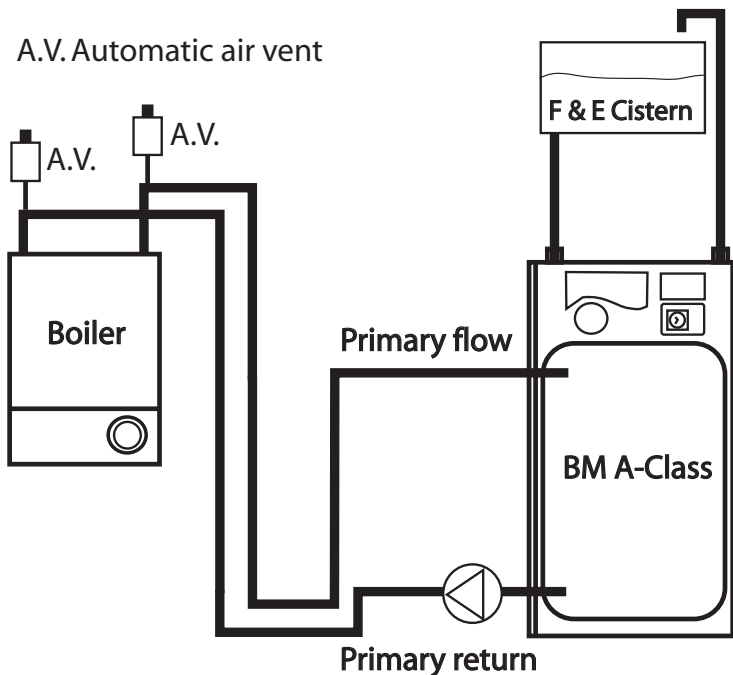

Boiler sited with dipped flow and return pipes to the BoilerMate

Any boiler must be fitted with an overheat thermostat i.e. it must be approved for use in a sealed system.

An automatic air vent will be required on the flow and return connections adjacent to the boiler.

The height of the water level in the F & E cistern must provide the minimum head required by the boiler and must be at least 250mm above the highest point of the system.

1.0 DESIGN

1.3 SYSTEM DETAILS

Heating System

Connection of Bathroom Radiator/ Towel-Rail for Summer use

If a pumped circuit is required for the bathroom radiator/towel rail, the flow pipework can be teed anywhere into the primary flow between the boiler and the BoilerMate. The return pipework can be connected into the 15mm copper blanked connection provided adjacent to the boiler pump. We recommend any radiators/towel rails on this circuit are provided with T.R.V.'s and that the total heat output of the radiators/towel rails is not more than the figure quoted in the table on page 5.

The radiators will only get hot when the boiler is firing.

It is important that the flow rates through these radiators is adjusted to the minimum required at the lockshield valves on the radiators. If this is not done the performance of the BoilerMate will be adversely affected.

The height of the water level in the F & E cistern must provide the minimum head required by the boiler and must be at least 250mm higher than the highest point of the system.

Alternatively, if full time control is required of the Summer/Towel rail circuits these can be piped as a separate zone from the main heating circuit with their own zone valve and programmable room thermostat as shown in Section 2.2 Installation, Zoned Heating Systems.

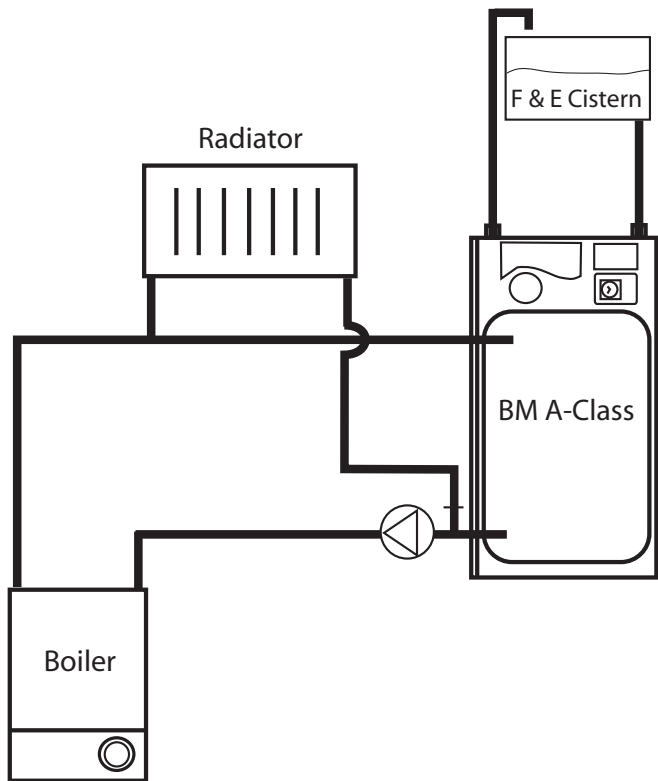

1.3 SYSTEM DETAILS

Heating System

Method of connecting two BoilerMates to one heat source.

If the primary flow and return pipework continuously rises from the boiler to the BoilerMate the recommended method for connecting two BoilerMates to one heat source is to fit the BoilerMates as normal but to provide a single check valve on the branch immediately after each primary pump.

The heating and hot water from each appliance must serve separate zones/bathrooms within the property.

The electrical supplies from each appliance to the boiler will need twinning so that the boiler will operate on a call from either/both appliances.

Both primary pumps and the primary pipework sizes should be checked to ensure that they are adequate for the system that has been installed.

The BoilerMate A-Class appliances will not be suitable if the primary pipework dips or the boiler is located above the BoilerMate.

For further details please ring the Gledhill Technical helpline.

1.0 DESIGN

1.3 SYSTEM DETAILS

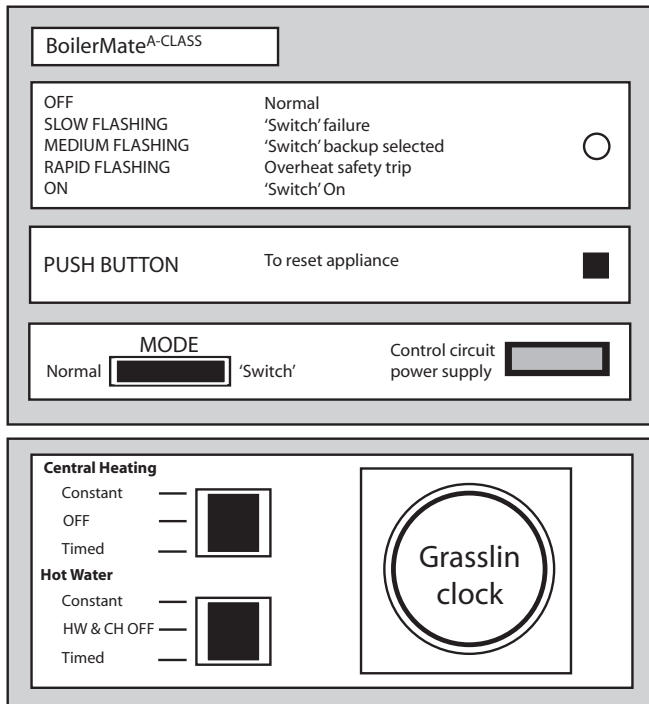

'Switch'

The BoilerMate A-Class is supplied with 'Switch' which provides a 6kW electrical emergency back up in the case of failure of the main heat source i.e. gas boiler.

This must NOT be used to provide hot water only in summer if the main system is working correctly.

Full details of the electrical requirements are provided in Section 2.1 Site Requirements and 2.2 Installation.

'Switch' will be activated by moving the mode rocker located on the front control panel into the 'switch' position (see diagram opposite). This replaces the function of the external boiler with the internal electric emergency boiler. The programming of space heating and store charging is still controlled by the clock and the hot water and central heating control rockers.

For emergency hot water only put the mode rocker into 'Switch' position, the hot water control rocker in the constant position and the central heating rocker to off.

For emergency hot water and heating put the mode rocker into 'Switch' position, the hot water and central heating control rockers in the constant position and the central heating rocker to off.

In this situation the store will charge and the space heating will be available at all times.

Once the fault has been resolved return to normal boiler operation by moving the mode rocker to the normal position and reset the hot water and central heating control rockers to the required position.

During Switch operation the central heating can be operated in a timed mode if required by setting the central heating control rocker to timed and the clock/programmer to suit the

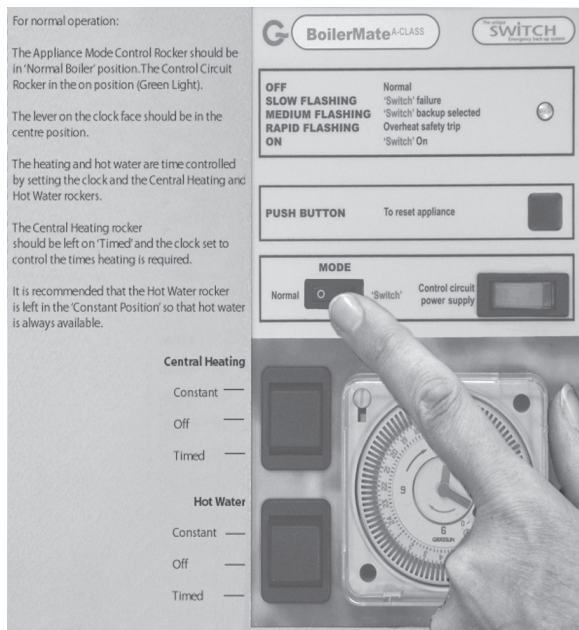

Put Mode Rocker to 'Switch' position

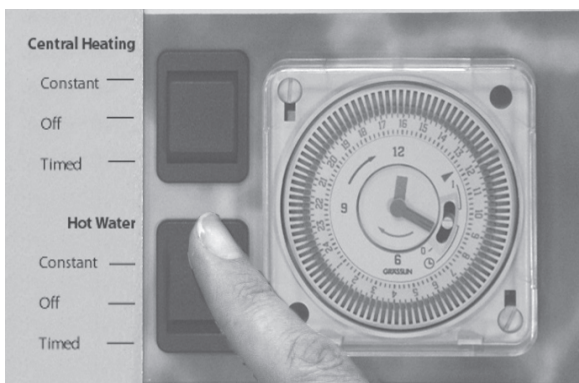

Select HW Only

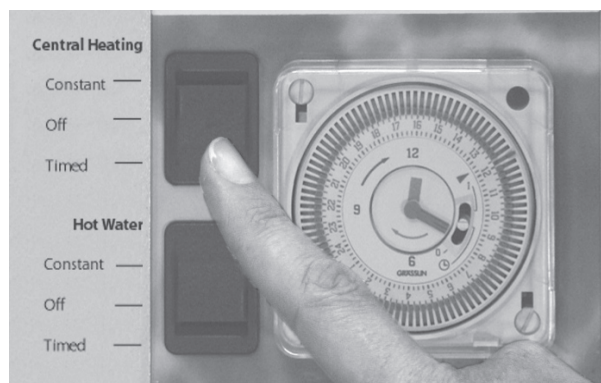

Select HW & CH

2.1 SITE REQUIREMENTS

The appliance is designed to be installed in an airing/cylinder cupboard and the relevant minimum dimensions are provided in section 1.2 Technical Data.

Because of the ease of installation we recommend that the cupboard construction is completed and painted before installation of the appliance. The cupboard door can be fitted after installation.

If the unit needs to be stored prior to installation it should be stored upright in a dry environment and on a level base/floor.

Installation and maintenance access is needed to the front of the appliance and above the F & E cistern. See Technical Data section for further details.

The minimum dimensions contained in section 1.2 Technical Data allow for the passage/connection of pipes under the appliance from any direction as long as the appliance is installed on the installation base provided. If the installation base is not used extra space may be needed to allow connection to the pipework and the whole of the base area should be continuously supported on a material which will not easily deteriorate if exposed to moisture.

The floor of the cupboard needs to be level and even and capable of supporting the weight of the appliance when full. Details of the weight when full is provided in section 1.2 Technical Data.

The appliance is designed to operate as quietly as practicable. However, some noise (from pumps etc) is inevitable in any heating system. This will be most noticeable in cupboards formed on bulkheads, or at the mid span of a suspended floor. In these cases the situation can be improved by placing the appliance on a suitable sound deadening material (i.e. carpet underlay or similar).

Cupboard temperatures will normally be higher than in a conventional system and the design of the cupboard and door will need to take this into account. No ventilation is normally required to the cupboard.

A suitable location will be needed for the separate feed and expansion cistern. This will often be at high level in the cupboard housing the BoilerMate A-Class. The dimensions and clearances are provided in section 1.2 Technical Data. The location will need to provide a suitable route for the cold feed and expansion pipe as well as the open safety vent pipe. The location will also need to provide a suitable route and discharge position for the warning/overflow pipe and the ballvalve supply from the mains cold water system.

An electrical supply must be available which is correctly earthed, polarized and in accordance with the latest edition of the IEE requirements for electrical Installations BS 7671.

The electrical mains supply needs to be 230V/50Hz.

Connection must be made using a double-pole linked isolator with a contact separation of 3mm in both poles which is located within 1m of the appliance. The supply must only serve the appliance.

The minimum breaking capacity of the main isolator cable sizes/lengths at 230V shall follow the recommendations in the table shown opposite.

If the boiler incorporates a frost thermostat an extra 3 core 3 amp supply cable will be required between the boiler and the BoilerMate to provide a supply to the boiler pump - see 2.2 Electrical Connection for further details.

Nominal full load current	Min rating of the isolator	Cable size	Max. recommended cable run-based on not exceeding 4% of the nominal voltage supply of 230 VAC using a type B breaker
28.5 Amps	32 Amps	6 mm ²	44 metres
Recommended circuit protection device - based on 0.4 second disconnection time		32 A type B circuit breaker to BS EN 60898 or 32A type B RCBO to BSEN 61009	

Electrical Supply requirements for BoilerMate A-Class

2.2 INSTALLATION

Preparation/placing the appliance in position.

Details of the recommended positions for termination of the first fix pipework are provided in section 1.2 Technical Data. The pipework can be located or its position checked using the template provided with each appliance. If these have been followed installation is very simple and much quicker than any other system.

The appliance is supplied shrink wrapped on a timber installation base. Carrying handles are also provided in the back of the casing.

The feed and expansion cistern complete with ballvalve, cold feed/expansion and overflow/warning fittings are provided in a separate box. If flexible connections have been ordered these will also be inside the feed and expansion cistern.

The appliance should be handled carefully to avoid damage and the recommended method is shown opposite. Before installation the site requirements should be checked and confirmed as acceptable. The plastic cover and protective wrapping should be removed from the appliance and the installation base (provided) and placed in position.

The appliance can then be lifted into position in the cupboard on top of the base and the front panel removed by unscrewing the 2 screws and lifting the door up and out, ready for connection of the pipework and electrical supplies. The feed and expansion cistern support shall be installed ensuring that the base is fully supported and the working head of the appliance is not exceeded and the recommended access is provided for maintenance - see section 1.2 Technical Data. For further information on manual handling See Appendix D.

Note: Although the above guidance is provided any manual handling/lifting operations will need to comply with the requirements of the Manual Handling Operations Regulations issued by the H.S.E.

The appliance can be moved using a sack truck on the rear face although care should be taken and the route should be even.

In apartment buildings containing a number of storeys we would recommend that the appliances are moved vertically in a mechanical lift.

If it is proposed to use a crane expert advice should be obtained regarding the need for slings, lifting beams etc.

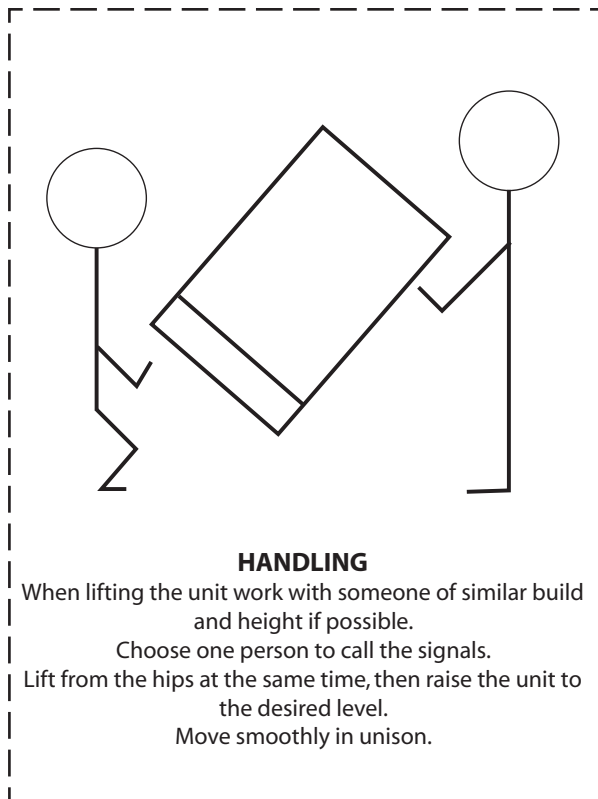

A specific manual handling assessment is shown in Appendix D at the rear of this manual.

2.2 INSTALLATION

Pipework connections

The position of the pipework connections is shown opposite. The connection sizes and dimensions are listed in Section 1.2 Technical Data.

All the connections are also labelled on the appliance. It is essential that the pipework is connected to the correct connection.

Connections A, B, C, E and G are plain ended copper pipe.

Connections D, F and H are compression fittings.

Connection I is RC $\frac{1}{2}$ ($\frac{1}{2}$ in BSPT internal).

Connection J is a blanked copper pipe.

- A - Safety open vent
- B - Cold feed/expansion
- C - Primary flow (from boiler)
- D - Primary return (to boiler)
- E - Central heating return
- F - Central heating flow
- G - Domestic hot water
- H - Incoming mains cold water
- I - Drain (valve is not provided with the appliance)
- J - Primary return for pumped summer towel rail circuit

Note: The safety open vent and cold feed/expansion should be connected to the F & E cistern using the pipework assembly provided.

All factory made joints should be checked after installation in case they have been loosened during transit.

The fittings for the feed and expansion cistern should be installed following the instructions provided in a position to suit the particular location and the cistern fitted on its supports/base.

The cold feed/expansion and safety open vent should be installed between the appliance and the feed and expansion cistern.

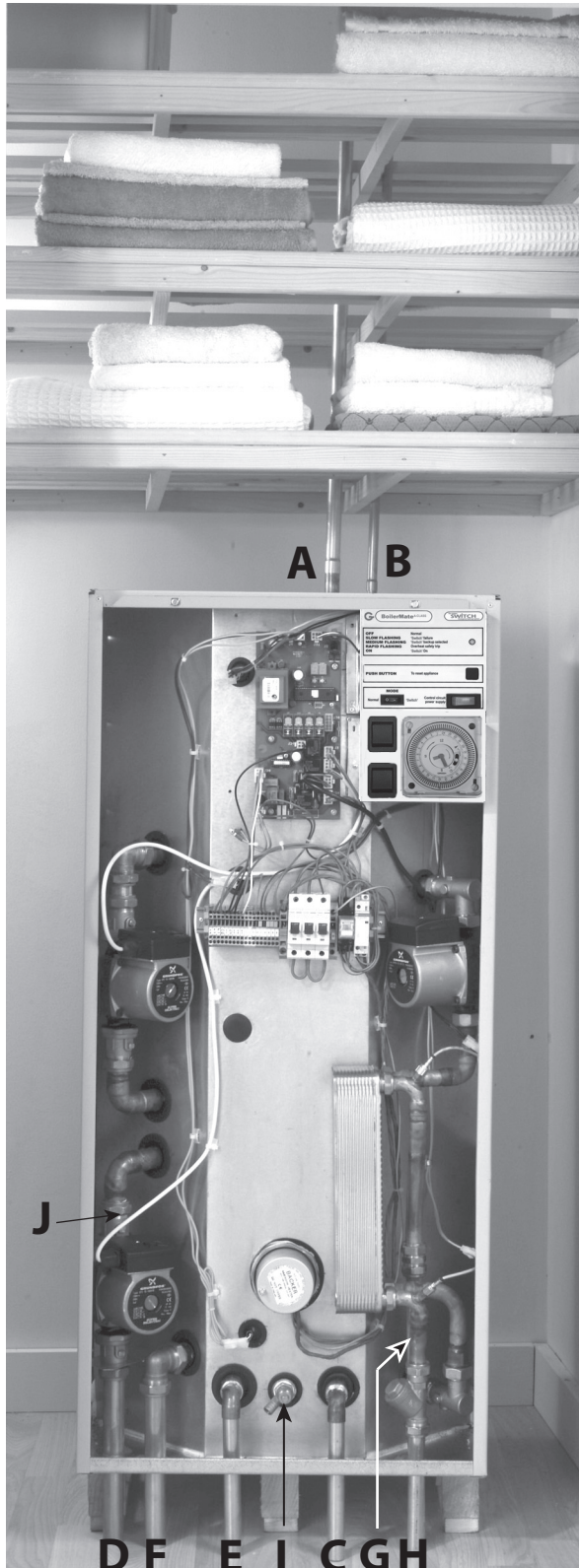

2.0 INSTALLATION

2.2 INSTALLATION

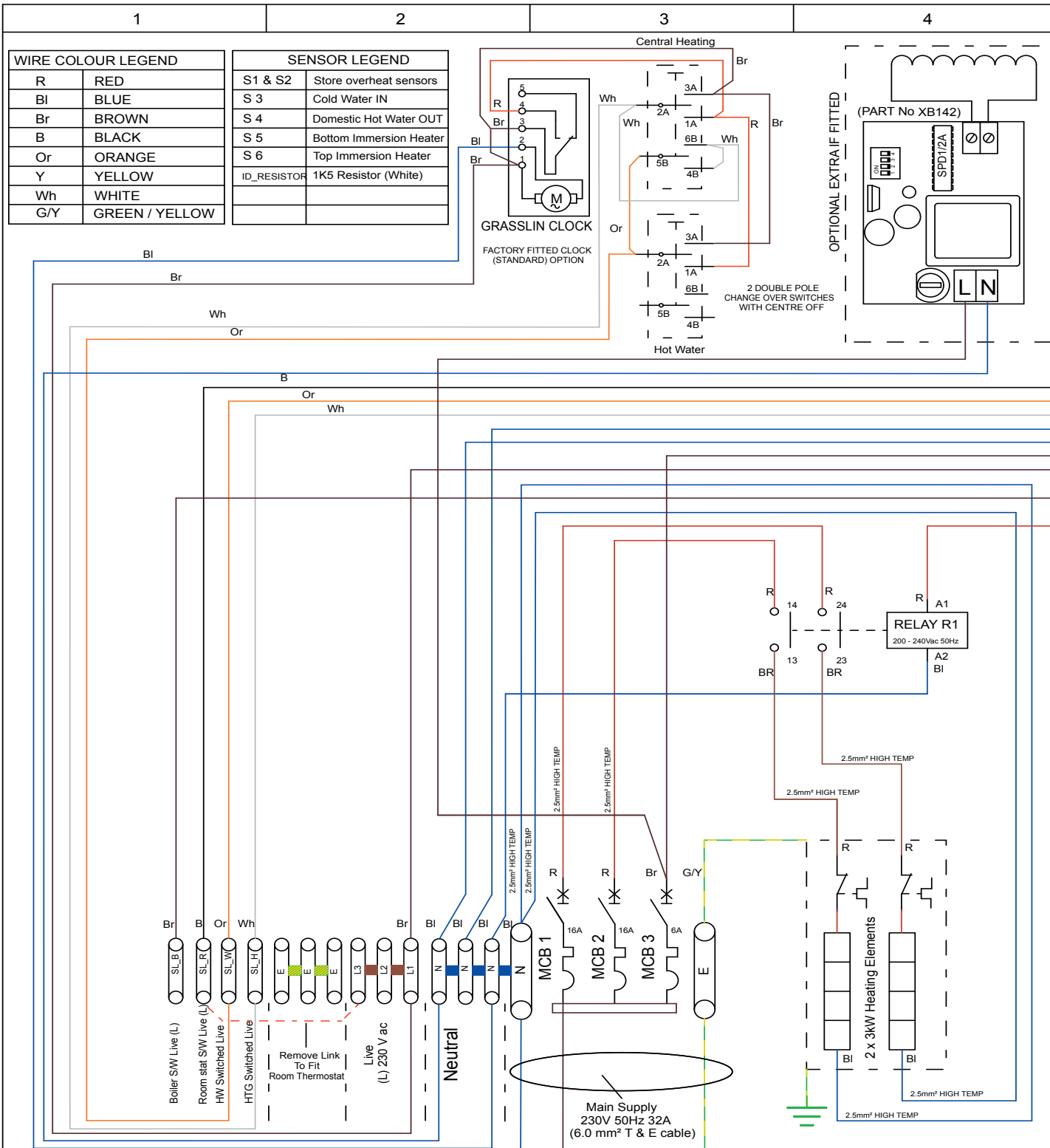

DRN. A.McEvilly	DATE 10-08-05	CH'KD. S. McGachie	SIGN.	DATE 10-08-05	APP'D. S. Gataora	SIGN.	DATE 10-08-05
DATE : AUGUST 2005		ISSUE No : 4			DO NOT SCALE FROM THIS DRAWING. COPYRIGHT OF THIS DRAWING IS RESERVED. IT IS NOT TO BE REPRODUCED COPIED OR DISCLOSED TO A THIRD PARTY EITHER WHOLLY OR IN PART WITHOUT OUR WRITTEN CONSENT. © GLEDHILL WATER STORAGE LTD.		
APPROVED							



2.0 INSTALLATION

2.2 INSTALLATION

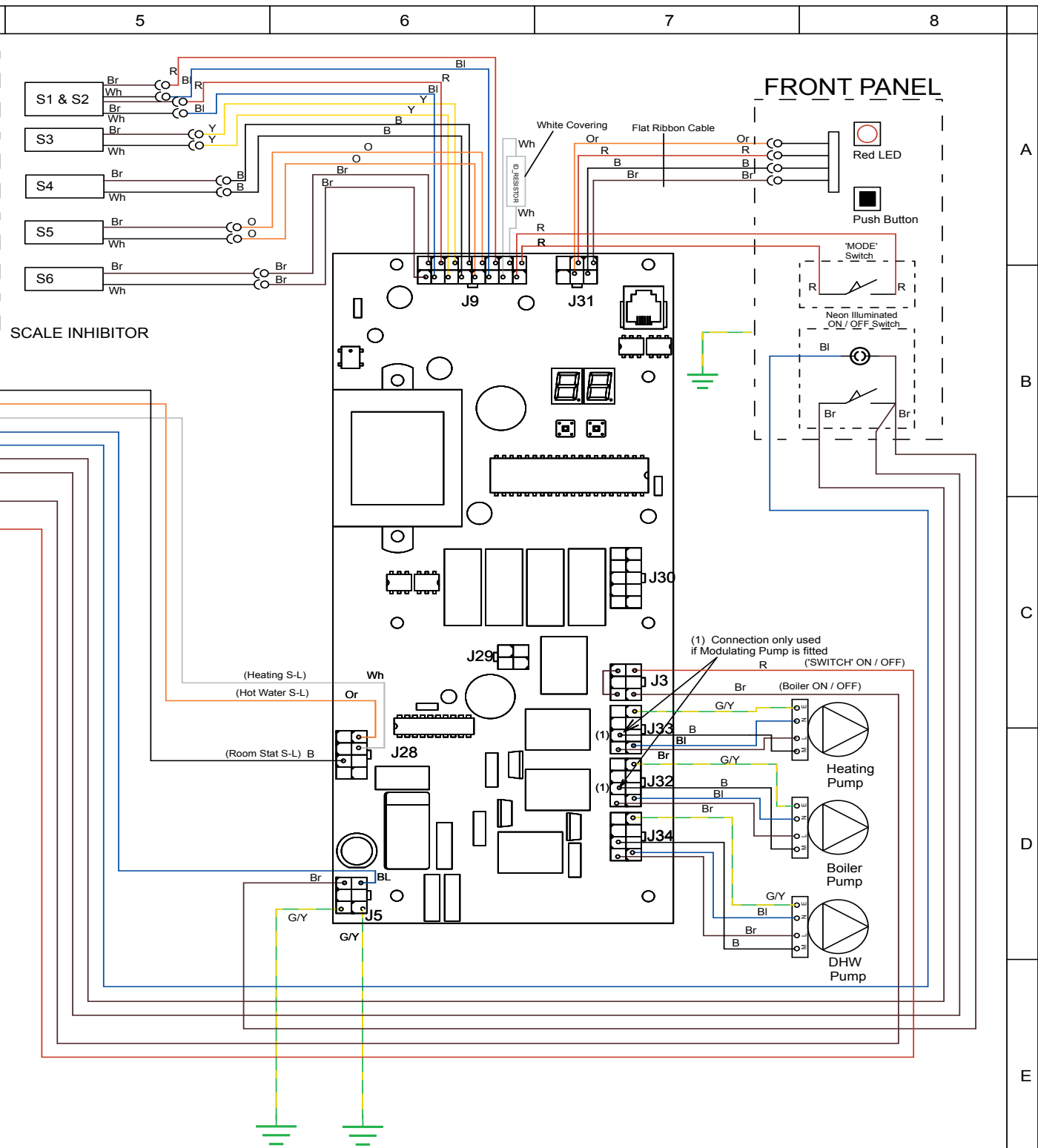

GLEDHILL WATER STORAGE LTD.
 SYCAMORE TRADING ESTATE
 SQUIRES GATE LANE
 BLACKPOOL
 LANCASHIRE
 FY4 3RL

TITLE
**BOILERMATE 'A' Class
 with Clock (Factory Standard)**

JOB NAME
 Electrical Schematic for BOILERMATE 'A' class
 appliance with factory fitted clock

DRG. SIZE
 A3

DRG. NAME
 'A' Class Boilermate ver 4.FC7

2.2 INSTALLATION

It is normally envisaged that the feed and expansion cistern will be located in the same cupboard as the BoilerMate appliance itself to maintain a dry roof space.

The cold feed/open vent pipework assembly (as supplied) should be used if it is intended to install the F & E cistern directly on top of the appliance

However, if it is necessary to locate the cistern in the roof space (or on a higher floor) the cold feed/open vent pipework assembly (as supplied) should be used to connect to the F & E cistern and pipework site run by the installer to connect this to the appliance.

Obviously, any pipework in the roof space and the feed and expansion cistern will need to be adequately insulated to protect against frost damage.

Combined feed and open vent pipe arrangements must not be used.

No valves should be fitted in the safety open vent which must be a minimum of 22mm copper pipe or equivalent.

The overflow/warning pipe shall have a continuous fall, be fitted to discharge clear of the building and be sited so that any Overflow can be easily observed. It shall also be installed in a size and material suitable for use with heating feed and expansion cisterns in accordance with BS 5449 and should not have any other connections to it.

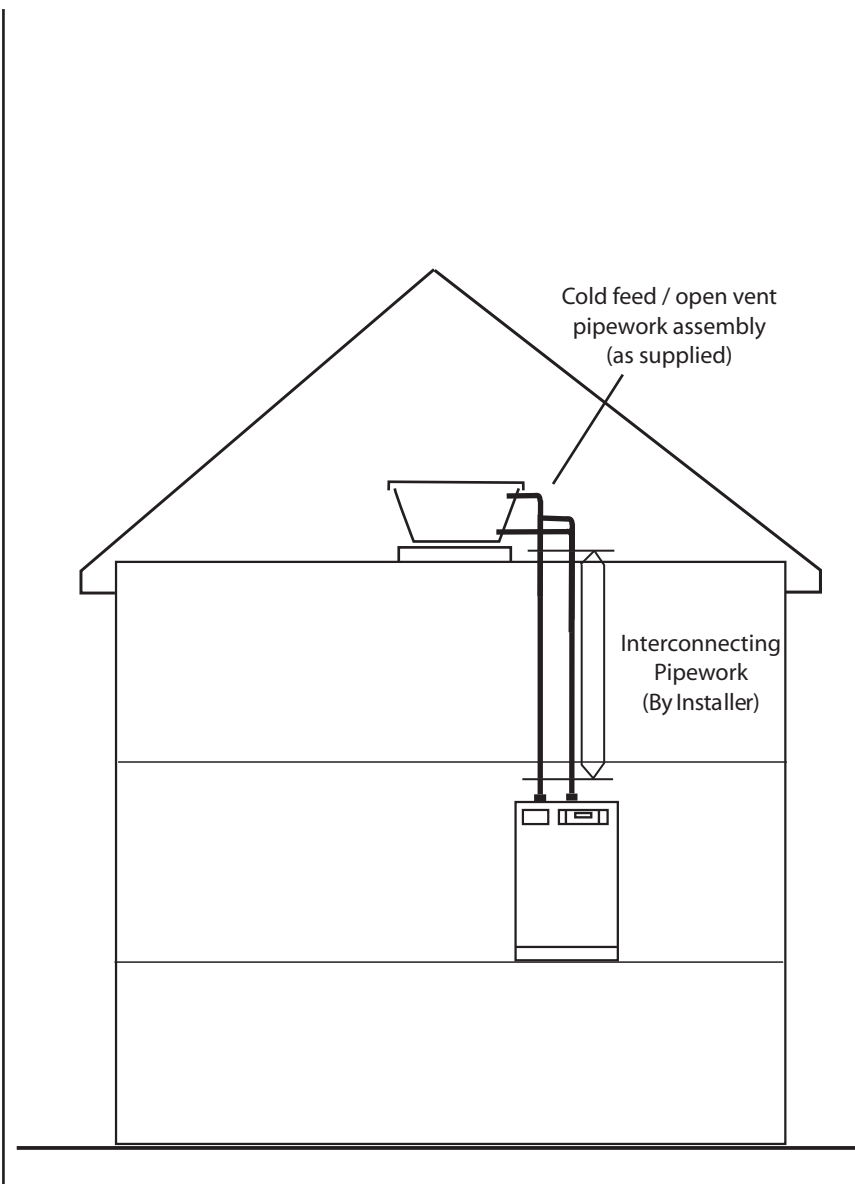

2.2 INSTALLATION

Electrical Connection - Standard Appliance

The BoilerMate A-Class OV is pre-wired to DIN rail terminals from the A.C.B. and plumbers are well able to complete the electrical installation provided they adhere strictly to the IEE Requirements for Electrical Installations BS 7671.

All the terminals are suitably labelled.

Note: Do not attempt the electrical work unless you are competent to carry it out to the above standards.

Before commencing check that the power source is in accordance with section 1.2 Site Requirements and ensure that it is isolated.

Run the external wiring through the service slot provided in the base of the appliance.

The 2 & E core input cable from the isolator to the appliance must not be less than 6mm² PVC grade to BS 6500.

This supply cable must be fed via a 32 amp double pole isolator no more than 2 metres from the appliance.

Make the connections as shown opposite.

The appliance is provided with a link between terminals SL_R and L2 on the terminal connections. This must be removed if a room thermostat is fitted see opposite.

Clamp the cables in the grips provided below the terminal connections and ensure all cables are routed to avoid hot surfaces.

Note: The appliance is provided with a 4.0mm earth cable from an earthing strap on the primary return (to boiler) pipe to the earth stud on the wiring panel.

The supply to the BoilerMate A-Class must be protected by a type B MCB to BS EN 60898 of at least 32 amps rating.

Two installer supplied flex cables are required to connect external room thermostat and boiler. These cables must each be 4 core and at least 1mm² or above in size.

For maintenance purposes it is essential that an all pole isolator is positioned within 2 metres of the remote boiler installation, this helps in future maintenance to current Corgi requirements.

BOILERMATE 'A' CLASS EXTERNAL CABLE CONNECTION DIAGRAM

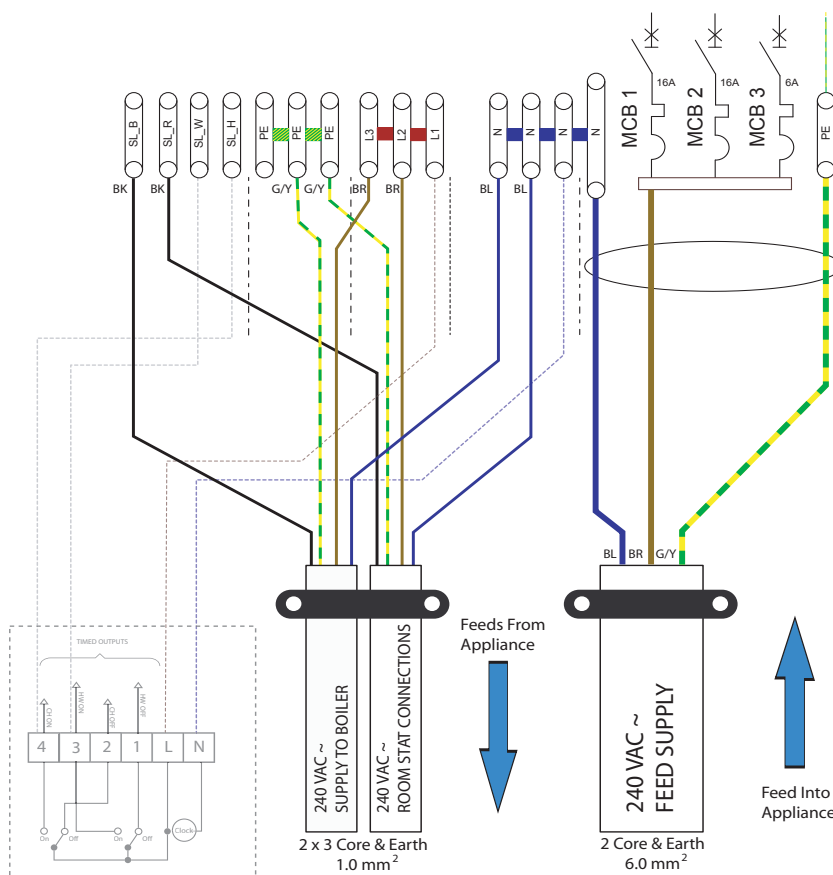

On a 'No Clock Option' an external 2 channel controller must be supplied separately and connected as above.
(Factory Fitted Links between L1-SL_H-SL_W will need to be removed)

INSTALLER ELECTRICAL CONNECTIONS

2.2 INSTALLATION

The BoilerMate A-Class incorporates a pump overrun for the boiler pump and terminal L1 on the terminal strip (as shown on page 23) should only be used if the boiler requires a permanent live for another purpose.

The boiler manufacturers wiring instructions should be read in conjunction with this manual.

Before switching on the electrical supply check all the factory made terminal connections to ensure they have not become loose during transit.

Frost Protection

When frost protection is required for the whole house or where a base temperature is required during cold weather, the programmer should be set to constant during the time required and the room thermostat adjusted to a suitable setting.

When the location of the boiler means that frost protection is required the boiler specified should incorporate its own integral frost thermostat.

Important

When the boiler has an integral frost thermostat fitted it will be necessary for the primary pump to be powered from the pump connections within the boiler. In this case the primary pump flex should be unplugged from the controller PCB at connector point J32 (see wiring diagram for location) then the plug and flex should be removed from the pump terminals. A connection from the boiler pump connections L, N, E should be made to the L, N, E terminals of the primary pump. This will need an additional three-core cable running between the boiler and BoilerMate.

Main boiler cable from BoilerMate, all boilers require a SL, N & E, some boilers will also need a L

Pump output cable to be wired direct to the primary pump on the BoilerMate when the boiler has integral frost protection

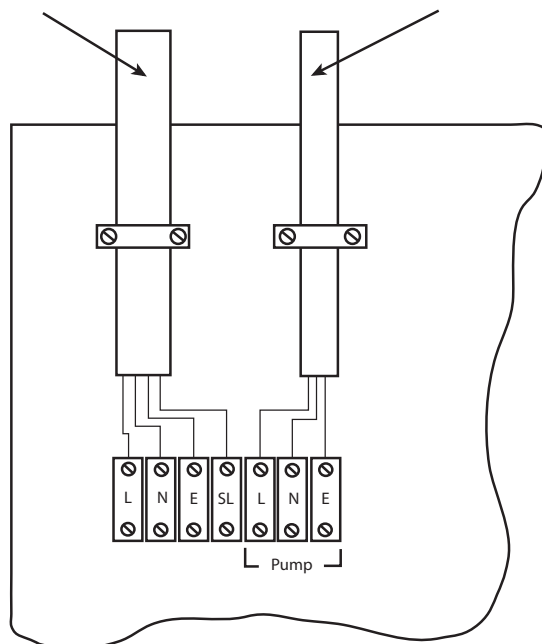

Typical boiler wiring terminals and cable connections

2.0 INSTALLATION

2.2 INSTALLATION

Electrical Power Supplies - BoilerMate A-Class with Switch.

WARNING: THE BOILERMATE A-CLASS IS FITTED WITH AN ELECTRIC BACKUP SYSTEM 'SWITCH'.

IMPORTANT: ELECTRICIAN/INSTALLER PLEASE NOTE.

THE 2 x 16A MCB's (MCB1 and MCB2) FOR THE 'SWITCH' ELECTRIC BACKUP SYSTEM ARE SUPPLIED SET IN 'OFF' POSITION. THE GAS BOILER CAN BE COMMISSIONED WITHOUT SWITCHING THESE ON.

IT IS IMPORTANT THAT THE GAS BOILER IS COMMISSIONED BEFORE TESTING OR USING EMERGENCY SWITCH FACILITY.

AFTER THE GAS BOILER HAS BEEN COMMISSIONED CUT AND REMOVE THE PLASTIC TIE AND MOVE THE MCB'S TO 'ON' POSITION TO COMMISSION THE SWITCH FACILITY.

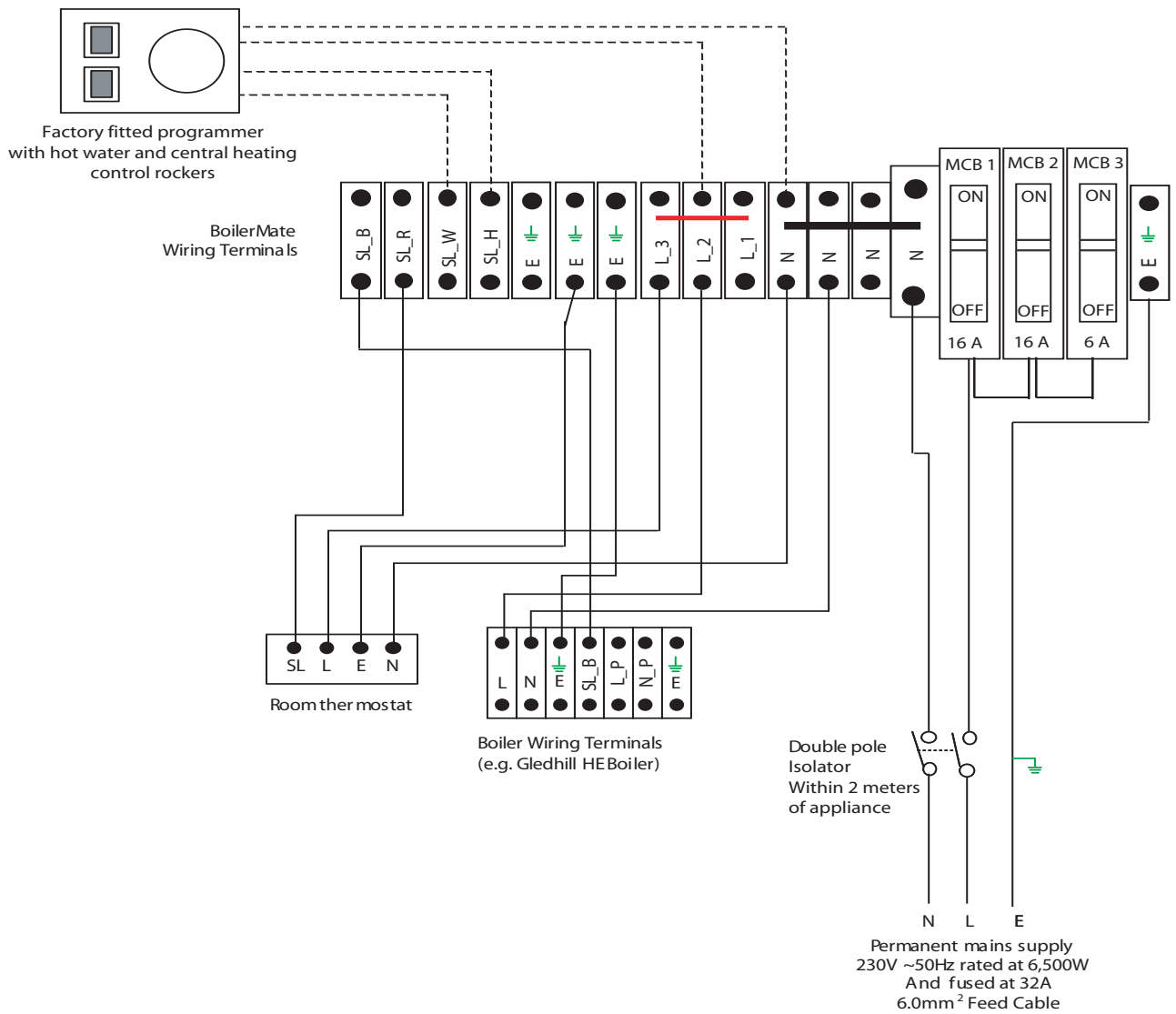

Typical external wiring of a standard BoilerMate with 'Switch'

2.0 INSTALLATION

2.2 INSTALLATION

Zoned heating systems

BoilerMate is available in a multi-zone version for use where a property has to have its space heating zoned. Where this appliance version is to be used it is recommended that the BoilerMate is located on a raised platform in the cupboard creating a space below the appliance to locate the zoning equipment. The recommended height of the platform from the floor is 250mm. The platform must be constructed in a material that will not easily deteriorate if exposed to moisture. It must also be capable of supporting the weight of the appliance when full. Details of the weight when full is provided in section 1.2 Technical Data.

Connecting the zones to the BoilerMate.

The space heating flow should be taken from the BoilerMate connection into the space below the platform. The flow can now be split into the appropriate amount of zones and a controlling zone valve fitted to each branch. Each flow can then be piped to its radiator zone and the heating return brought back to the space below the platform. The heating returns can now be connected together before a single connection is made to the heating return on the BoilerMate.

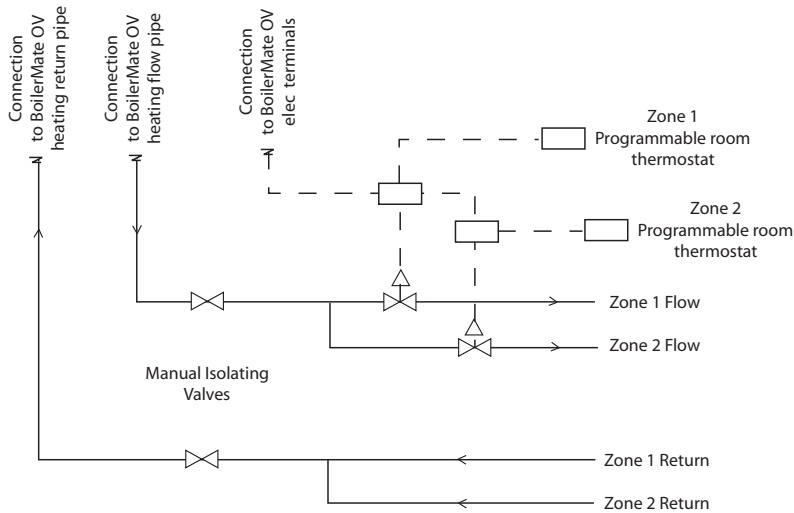

TYPICAL SCHEMATIC ARRANGEMENT OF MULTIZONE HEATING

NOTE: ONLY 2 ZONES ARE SHOWN FOR CLARITY BUT FURTHER ZONES CAN BE ADDED IN THE SAME WAY IF REQUIRED

BOILERMATE MULTI-ZONE EXTERNAL WIRING DIAGRAM

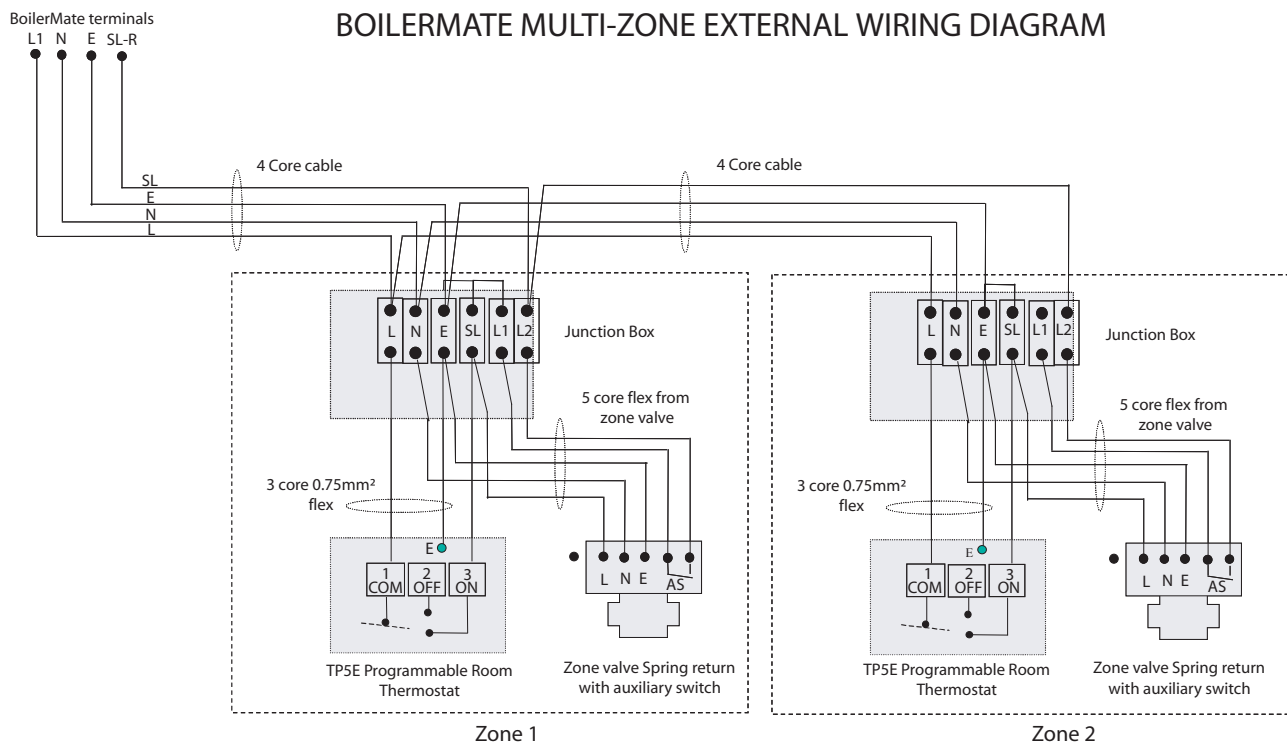

2.0 INSTALLATION

2.2 INSTALLATION

Multi-Zone Wiring Diagram

Electrical Schematic for a BoilerMate A-Class OV - Multizone Model
(Version 19/04/05)

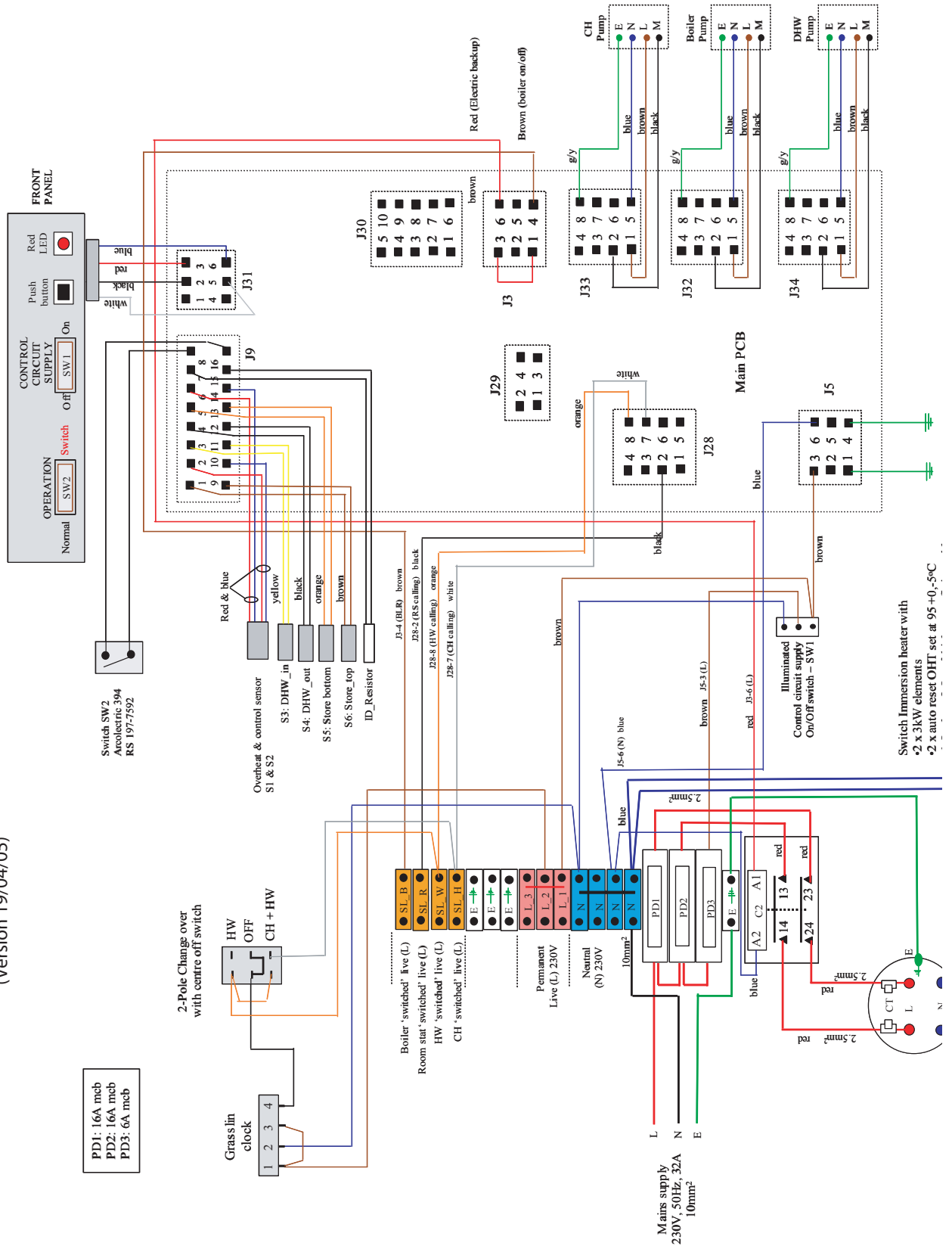

2.0 INSTALLATION

2.3 COMMISSIONING

Open the incoming stop valve and fill the domestic mains cold and hot water systems.

Fill the whole of the primary heating system with potable water through the feed and expansion cistern.

Check the water level in the feed and expansion cistern and adjust the ballvalve if necessary.

Check the whole of the primary heating and domestic hot and cold distribution system, including the boiler and BoilerMate OV, for leaks.

It is essential that all systems function properly for optimum performance.

To achieve this, the primary system should be commissioned in accordance with good practice and generally in accordance with the requirements of BS 6798, BS 5449 and BS 7593.

Full details of the requirements are given in PAS 33:1999 under Section 10 Commissioning.

Model	Volume to be added to the system (litres)	
	Corrosion inhibitor agent	
	Sentinel X100	Fernox MB1
BM125	1¼	1¼
BM145	1½	1½
BM185	2	2
BM210	2¼	2¼
BM225	2½	2½

Model	Volume to be added to the system (litres)	
	Cleansing agent	
	Sentinel X300	Fernox Superfloc
BM125	1½	1½
BM145	1½	1½
BM185	2	2
BM210	2¼	2¼
BM225	2½	2½

When using either cleansing or corrosion inhibitor chemical, the manufacturers instructions must be followed.

Cleansing the Primary System

When determining the quantity of cleanser required, be sure to allow for the increased volume of water in the primary circuit due to the thermal store - see section 1.2 Technical data for volumes.

In most cases the quantities shown opposite will be adequate for up to a typical 3/4 bedroom property.

Primary Water System Treatment

Although the BoilerMate has no special water treatment requirements, the radiators and other parts of the circuit will benefit from the application of a scale and corrosion inhibitor such as Sentinel X100 or a Protector such as Fernox MB1.

When determining the quantity of inhibitor required, be sure to allow for the increased volume of water in the primary circuit due to the thermal store - see section 1.2 Technical Data for volumes.

In most cases the quantities shown opposite will be suitable for up to a typical 3/4 bed property.

POWERFLUSHING/CLEANING OF THE HEATING SYSTEM

If it is proposed to 'powerflush' the heating system we would recommend that the BoilerMate appliance is isolated from the heating system being cleaned. Failure to do this could seriously damage the appliance.

When carrying out the work always comply fully with the manufacturers instructions for the powerflushing equipment being used.

If in any doubt please consult our Technical Helpline.

2.3 COMMISSIONING

Once the system is finally filled turn down the servicing valve for the ballvalve in the F & E cistern to the point where the warning/overflow will cope with the discharge arising from a ballvalve failure.

Cleansing Hot/Cold Water System Treatment

Fully flush and if necessary chlorinate the hot and cold water system in accordance with the recommendations in the Model Water Byelaws and BS 6700.

Commissioning the BoilerMate control system

For maximum system efficiency the store thermostat must be in control of the boiler i.e. the boiler cycles on the store thermostat and not on its integral thermostat. The BoilerMate control system will automatically commission itself to match the actual performance of the installed boiler. However the operation of the control system should be checked as follows.

(a) Check that the BoilerMate front panel mode rocker is in the 'normal' position. Put the hot water control rocker in the constant position and the central heating control rocker in the off position.

(b) The boiler will not start i.e there will be no 240V ac start signal at BoilerMate terminal 'SL-B' until:-

- The heating programmer calls for hot water /heating which will bring display segment V1.1 on, and
- Store sensors are calling for heat which will bring display segments H1.1 and H1.2 on (see opposite)

(c) Set the boiler thermostat to maximum and commission the boiler as per manufacturer's instructions and ensure that the flow temperature reaches more than 77°C before switching off. Display segments H2.3 and V2.1 will be on whilst the boiler is firing.

(d) Check and adjust the speed of the boiler pump to provide a differential temperature of not more than 8°C across the flow and return.

(e) Check on the A.C.B. that the appliance reaches a suitable temperature re above 75°C

(f) To manually check the 'switch' electric backup is working, move the mode rocker on front panel display from 'normal' to 'switch' position. The electric backup operation can now be checked. Draw a bath full of hot water from the appliance to lower the temperature and bring 'switch' into operation.

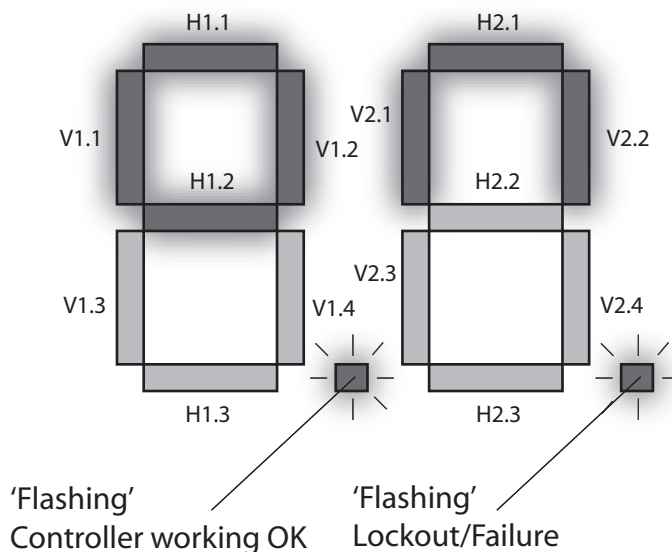

This is easily checked with the aid of a clamp meter that should show a current drawn of around 26 amp. If a suitable meter is not available a bath full of hot water should be drawn from the appliance after which the store temperature should be noted. With no further demand a rise in store temperature of 5 – 10°C in about 15-20 minutes (dependent on store size) should be observed. Display segment V2.2 will be on whilst 'Switch' is working. Once it has been proved that 'switch' is working move the mode rocker switch back to the normal position.

Note: If both 'dots' are flashing then the controller is working. However it is a warning of limited/alternative control functionality

LED	Description
H1.1	Middle store sensor calling for heat
H1.2	Bottom store sensor calling for heat
H1.3	Spare
V1.1	HW Programmer calling for heat
V1.3	CH Programmer calling for heat
V1.4	Room thermostat calling for heat
H2.1	PHE pump on
H2.2	CH Pump on
H2.3	Boiler system pump on
V2.1	Boiler on
V2.2	Switch on / electric boost on
V2.4	Boiler boost mode on

2.3 COMMISSIONING

Commissioning Space Heating

(a) The central heating is best commissioned when the store is hot and therefore should be carried out after commissioning the BoilerMate.

(b) Move the central heating control rocker to the constant position, set heating programmer to continuous and ensure that the room thermostat is calling for heat. This will be indicated by display segments V1.3 and V1.4 being on respectively. The BoilerMate controller will now:-

• Turn on the central heating pump and this will be indicated by display segment H2.2 being lit.

(c) Wait until the heating circuit has reached its normal temperature before balancing the system in the usual way to achieve a temperature drop of about 10°C.

(d) Set the programmer and room thermostat as per manufacturer's instructions supplied with the appliance and ensure that the programmer instructions along with the user instructions for the appliance are left with the user.

Commissioning Domestic Hot Water System

(a) When the store is hot, open a hot water tap nearest to the appliance at approximately 6 litres/minute. After about 2 – 3 seconds, the plate heat exchanger pump will start. This is indicated on the A.C.B. by display segment H2.1.

(b) The hot water flow temperature should settle at about 52°C. Close this tap and open the hot bath tap at maximum flow rate and record the flow rate and the hot water temperature in the 'Benchmark' logbook.

(c) Close the hot water tap(s) and after few seconds, the plate heat exchanger pump will stop running and display segment H2.1 will turn off.

(d) It is recommended that the hot water rocker is left on constant so that hot water is always available. The central heating rocker should be left on timed and the clock set to control the times heating is required.

Hand over to User

- Explain the system and the BoilerMate appliance controls to the user.
- Explain how to operate the heating and hot water controls to the user. This should include setting 'on' and 'off' times and the room temperature on the room thermostat as well as the use of thermostatic radiator valves.
- Advise on boiler operation and maintenance advised in the boiler manual.
- Explain how to select and check the operation of the emergency backup electric boiler 'switch operation' - if there is a failure of the boiler.
- Handover appliance and room thermostat user instructions and put the completed "Benchmark" logbook and the appliance instruction manual in the pocket on the inside of the appliance front panel.
- DON'T place any clothing or other combustible materials against or on top of this appliance.

This product is covered by the 'Benchmark' scheme and a separate commissioning/service log book is included with this product. This must be completed during commissioning and left with the product to meet the Warranty conditions offered by Gledhill.

These Instructions should be placed along with the component manufacturers instructions in the pocket provided on the rear of the front panel. The front panel should then be refitted.

Important Do's and Don'ts

- DO** check the incoming mains water pressure and flow rate are adequate. (The preferred range of mains pressure is 2-3bar).
- DO** check that all connections are in accordance with the labelling on the thermal store.
- DO** adjust the ballvalve so that the water level in the F & E cistern when the system is cold is correct and does not overflow when the whole of the system is at maximum temperature.
- DO** make sure that there is adequate clearance above the F & E cistern to service the ballvalve.
- DO** ensure that the range rated appliances are set at the **highest output** and the boiler thermostat is set to **maximum** for all boilers.
- DO** ensure that the water level in the F & E cistern is at least 250mm above the highest point on the radiator circuit or the highest point of the system.
- DO** insulate any exposed pipework in the BoilerMate cupboard.
- DO** plumb the overflow/warning pipe in a 20mm internal diameter pipe material which is suitable for use with a heating F & E cistern, in accordance with BS 5449 (such as copper) and ensure it has a continuous fall and discharges in a conspicuous external position.
- DO** check the pump settings
 - The boiler pump should be set to give a temperature difference across the boiler of 8°C or less.
 - The heating pump should be set to give a temperature difference across the flow and return of not more than 11°C.
 - The hot water plate heat exchanger pump should be set at **maximum**.

2.3 COMMISSIONING

10. **DO** ensure that the bypass valve for the heating system (if fitted) is set correctly.

11. **DON'T** use a combined feed and vent on BoilerMate installations.

12. **DON'T** use a BoilerMate on a sealed primary i.e. closed system.

13. **DON'T** use pipe smaller than 28mm between the boiler and the BoilerMate when the boiler rating exceeds 20kW (about 68,000 Btu/h).

14. **DON'T** use dipped flow and return between the boiler and the BoilerMate unless the boiler is fitted with an overheat thermostat. If necessary check with the suppliers of the boiler.

15. **DON'T** operate the 'switch' backup facility until the system is fully fitted, vented and commissioned.

16. **DON'T** place any clothing or other combustible materials against or on top of this appliance.

3.0 SERVICING

3.1 ANNUAL SERVICING

No annual servicing of the BoilerMate A-Class is necessary.

However, if required, the operation of the controls and a hot water performance test can be carried out when servicing the boiler to prove the appliance is working satisfactorily and within its specification.

3.2 CHANGING COMPONENTS

Free of charge replacements for any faulty components are available from Gledhill during the in-warranty period (normally 12 months).

After this, spares can be obtained direct from Gledhill using the 'Speed Spares' service, or through any of the larger plumbers merchants/ specialist heating spares suppliers.

Help and advice is also available from the Technical Helpline on 01253 474401.

However, all components are readily accessible and can be changed quickly and easily by the installer using common plumbing practice.

Note:

The PHE pump is a Grundfos UPR 4 wire type and any replacement must be the same model.

This type of pump is also available as an option for the boiler and heating pumps. Be sure to check this and replace on a like for like basis.

3.0 SERVICING

3.3 SHORTS PART LIST

Key No.	Description	Supplier/Components	Stock Code No	Models	Gas Council No.
1	PHE pump	Grundfos UPR 15-50 (modulating)	GT089	All	
2	Plate heat exchanger (PHE)	SWEP 24 Plate heat exchanger	GT017	All	
3	PHE pump isolating valve - inlet	Martin Orgee	GT133	All	
4	PHE pump isolating valve - outlet	Martin Orgee	GT135	All	
5	CW inlet Y-line strainer		XB314	AI	
6	Boiler pump	Grundfos, UPR 15-50 (optional)	XB004	125, 145, 185	
		Grundfos, UPS 15-60 (standard)	XB241	210, 225	
7	Central heating pump	Grundfos, UPR 15-50 (optional)	XB004	125, 145, 185	
		Grundfos, UPS 15-60 (standard)	XB241	210, 225	
8	Boiler pump isolating valves	Vemco - Inlet	XB121	125, 145, 185	
		Vemco - Outlet	XB121	125, 145, 185	
		Vemco, Inlet & Outlet	XB122	210, 225	
9	Central heating pump isolating valves	Vemco - Inlet	XB121	125, 145, 185	
		Vemco - Outlet	XB121	125, 145, 185	
		Vemco, Inlet & Outlet	XB122	210, 225	
10	1 x 6 kW switch immersion heater	Backer	XB084	All	
11	Main PCB controller	Pijnenburg	GT490	All	
12	Bottom store sensor	Tasseron	GT198	All	
13	Middle store sensor	Tasseron	GT198	All	
14	Top (OHT) sensor	Duplex	GT199	All	
15	Front panel display	R H Technical	XB414	All	
16	Front panel display wiring harness	R H Technical	XB057	All	
17	Internal fuses/circuit protection	Control circuit 16A x 2	XG175	All	
		Switch circuit 6A x 1	XB025	All	
18	Switch contactor	Relay Base	XB299	All	
		Relay	XB298		
19	DIN Rail terminals	Wago	NSI	All	
20	Complete DIN rail assembly	Wago		All	
21	Complete wiring harness			All	
22	On-Off rocker	Arcoelectric	CA006	All	
23	Programmer EMC	Grasslin	XB215	All	
24	Central heating and hot water rocker	Arcoelectric	XB059	All	
25	DHW In/Out Sensor x 2	Tasseron	GT198	All	

3.4 FAULT FINDING

Despite everyone's best efforts some problems could occur and lead to complaints from the householder.

Complaints can be grouped into the following three main categories:-

1. The system is noisy
2. Hot water service is unsatisfactory
3. Space heating is unsatisfactory

The following checks should be carried out by the installer before calling the manufacturer.

1. Causes of a 'Noisy' System

Noisy pump operation

Check the level of water in the F & E cistern - adjust and vent the pump/system if necessary.

Check the pump speed setting of the boiler pump - reduce if necessary but ensure that the temperature rise across the boiler does not exceed 8°C.

Check the pump speed setting of the heating pump - reduce if necessary but ensure a temperature difference across the flow and return does not exceed 11°C.

Check and adjust if necessary the heating system bypass valve.

Check that the radiators are correctly balanced.

Noisy boiler operation

Check the flow rate through the boiler at full gas rate by measuring the temperature rise across the boiler. If the temperature rise is greater than 8°C, then increase the pump speed.

Check the level of water in the F & E cistern and the working head on the boiler.

Check and vent the system if necessary.

Noise when hot water tap is opened

If the plate heat exchanger pump is noisy when the hot water tap is opened, then check the level of water in the F & E cistern and vent the pump if necessary.

Water hammer - loose pipework and/or tap washers.

2. Causes of 'Unsatisfactory Hot Water Service'

Check that the BoilerMate is full of water i.e. level of water in the F & E cistern is correct when system is cold.

Check boiler thermostat - this should be set at maximum.

Check that the boiler flow temperature is adequate when it stops firing. Boilers should provide a flow temperature of $82 \pm 3^\circ\text{C}$ but temperatures as low as 75°C will allow the BoilerMate A-Class to provide a satisfactory performance.

Check that the store is charging to at least 75°C .

Check that the hot water plate heat exchanger pump stops and starts when the hot water tap is opened and closed.

Check that the plate heat exchanger pump is set at maximum speed.

Check that the space heating and hot water load is not greater than the boiler output and that the BoilerMate A-Class model is suitable for the type of dwelling.

If all the above checks are satisfactory then it is possible that the performance of the heat exchanger is impaired by scale. In this case the hot water flow rate will be noticeably less than the cold water flow rate. Replace with a factory exchange unit and re-check hot water performance.

3. Causes of 'Unsatisfactory Space Heating'

Check the boiler thermostat - this should be set at maximum.

Check that the boiler flow temperature before it is turned off by its own internal thermostat or the store sensor is adequate - it should not be less than 77°C .

Check the operation and the settings of the heating programmer and the room thermostat.

Check that the heating system pump is circulating the water to the radiator circuit.

If some rooms are not being heated properly, then balance the system/check the operation of the thermostatic radiator valves (if fitted).

Overflow from Feed and Expansion Cistern

Check that the controlled level of water in the cistern is no higher than necessary. Adjust if required.

POWERFLUSHING/CLEANING OF THE HEATING SYSTEM

If it is proposed to 'powerflush' the heating system we would recommend that the BoilerMate appliance is isolated from the heating system being cleaned. Failure to do this could seriously damage the appliance.

When carrying out the work always comply fully with the manufacturers instructions for the powerflushing equipment being used.

If in any doubt please consult our Technical Helpline.

Note: If the A.C.B. board is replaced it will need setting to the appliance type - see pages 9 and 10 for further details.

The system controls/operation should then be checked.

If the problem cannot be resolved the switch emergency electric backup should be switched on and operated in accordance with the instructions on the label fitted to the appliance until the installer/manufacturer can attend.

When requesting a visit from the manufacturer the installer must have the completed 'Benchmark' commissioning/service record sheet to hand to enable help to be provided.

WATER SAVINGS

WATER RELATED COSTS CAN BE REDUCED BY GOOD PLUMBING PRACTICE.

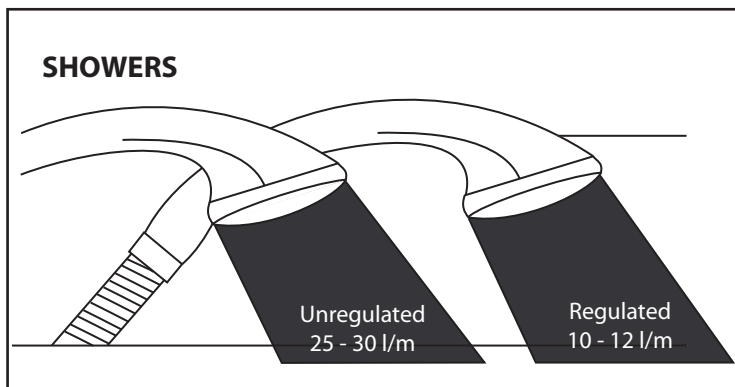
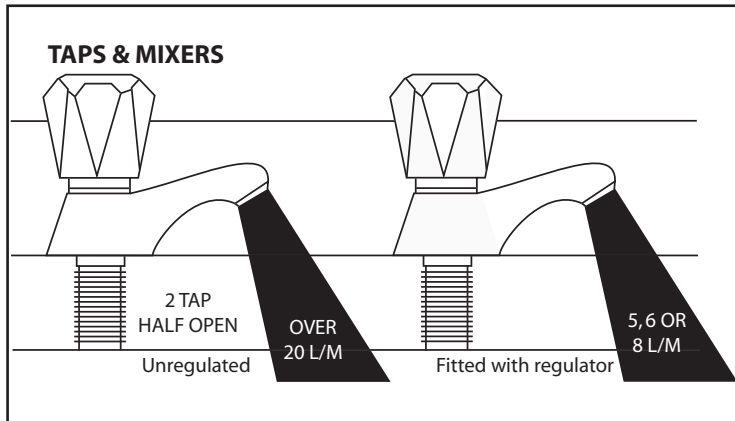

Vast quantities of water are needlessly run off to waste due to Taps, Mixers and Showers discharging flow rates far in excess of the rates required for them to perform their duties.

The contrasting flow rates shown on this leaflet clearly illustrate the savings that can be made whilst still providing a good performance.

British made Aquaflow Regulators provide constant flow rates by automatically compensating for supply pressure changes between 1 bar & 10 bars.

To facilitate installation into the wide range of plumbing equipment which is encountered in the U.K, Four Fixing Options are available:-

OPTIONS FOR SHOWERS

1. MXF "DW" Range - For fitting behind Fixed Shower Heads or onto Flexible Hoses for Handshowers (preferably onto the inlet end when lightweight hoses are used).
2. Compression Fitting Range. "In Line" regulators as in Option 4 for Taps & Mixers.

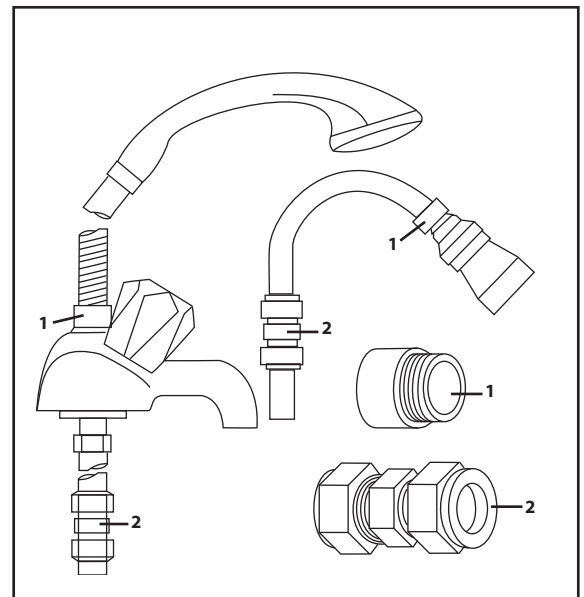

4 FIXING OPTIONS FOR TAPS & MIXERS

1. MK Range - Combined Regulators & Aerator for screwing onto Taps & Mixers with internal or external threads on their noses. Anti Vandal models also available.
2. MR05-T Range - Internal Regulators. Push-fit into Tap or Mixer seats. Produced in three sizes - 12.5mm (BS1010), 12mm & 10mm, Flangeless models also available for Taps with Low Lift washers.
3. MXF Standard Range - Screw on tail models for Taps & Mixers. Fix onto the tails before fitting the tap connectors. Available in 3/8", 1/2", 3/4" and 1" BSP.
4. Compression Fitting Range - "In Line" regulators housed in 15mm & 22mm CXC Couplers & Isolating Valves. UKWFS listed by the Water Research Centre. Isolation valves available for slotted screwdriver operation or with coloured plastic handles. Now available also in plastic bodied push-fit couplers & valves.

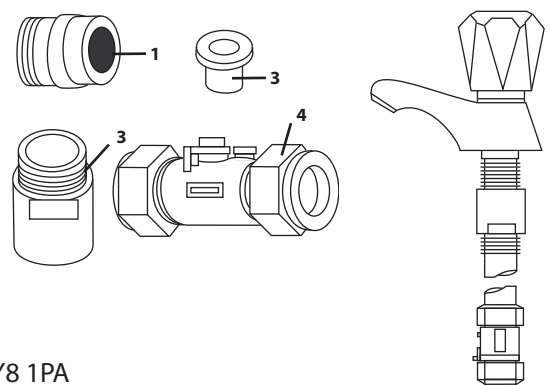

Information by courtesy of

AQUAFLOW REGULATORS LTD

Haywood House, 40 New Road, Stourbridge, West Midlands DY8 1PA
TELEPHONE (01384) 442611 FAX: (01384) 442612

APPENDIX B

MANIFOLDS

Manifold type: 1 - Stock Code MIP 050 (one bathroom, one en suite shower room, one cloakroom)			
Flow regulator (litres/minute)	Terminal fitting	Hot water manifold outlets Quantity	Cold water manifold outlets Quantity
18	Bath tap	1	1
8	Hand basin	3	3
10	Kitchen sink	1	1
8	Toilet cistern	None	3
8	Shower	1	1
8	Washing machine	1	1
8	Dishwasher	None	1
Total		7	11

Two sets of manifolds are available as an optional extra. Each set comprises a separate hot and cold water manifold. Both are provided with a 22mm inlet connection located centrally. All outlet connections are 15mm compression. The centre to centre dimension of each branch is 55mm.

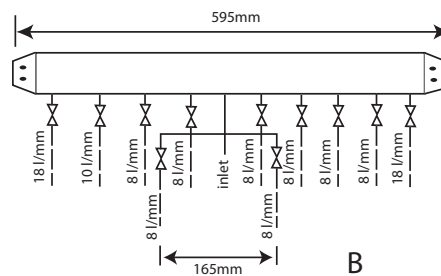
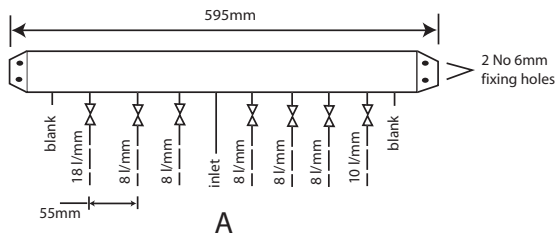

Manifold type: 2 - Stock Code MIP 060 (two bathrooms, one en suite shower room, one cloakroom, one utility room)			
Flow regulator (litres/minute)	Terminal fitting	Hot water manifold outlets Quantity	Cold water manifold outlets Quantity
18	Bath tap	2	2
8	Hand basin	3	3
10	Kitchen sink	2	2
8	Toilet cistern	None	3
8	Shower	1	1
8	Washing machine	1	1
8	Dishwasher	None	1
Total		9	13

The arrangement of each manifold is supplied as shown. This provides the best balance of flows but the flow regulators/duty of each branch can be changed if required as long as a reasonable balance is maintained. If it is necessary to change or clean the flow regulator this can be done without needing to drain the system by closing the valve and removing the screwed cover below the white plastic cover.

The manifolds are designed to be used with plastic pipework and are supplied complete with isolation valves and flow regulators on each branch. They would normally be installed in the same cupboard as the thermal storage appliance (as shown below) but can be installed in another cupboard close to the appliance if required.

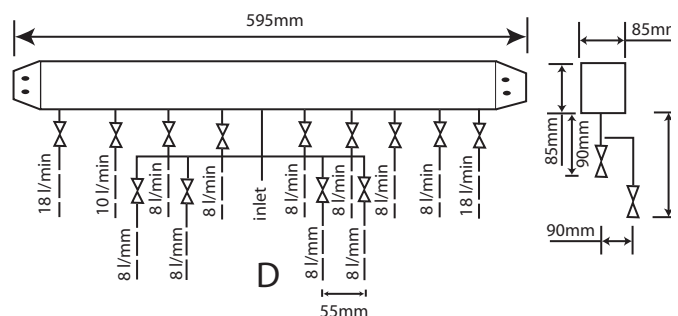
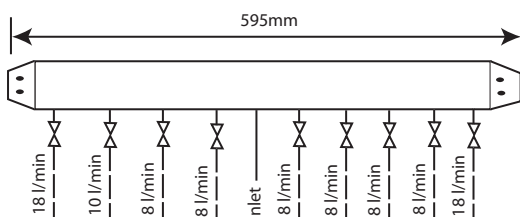

APPENDIX B

An optional location where cupboard space is tight



The preferred solution where space will allow

The pressure loss through a flow regulator at the designated flow rate is about 1.8 bar. Therefore for the flow regulator to control the flow rate at pre-set level, the inlet pressure must be greater than 1.8 bar. If the inlet pressure is lower, the flow rate will be correspondingly less than the pre-set values.

The maximum equivalent pipe lengths from the manifold to the terminal fittings can be estimated from the above information and the resistance characteristics of the pipes. The examples presented below are for 15mm copper pipe in table 1 and for plastic pipework in table 2.

Table 1 : Maximum equivalent pipe length in 15mm copper

Inlet pressure (bar)	Maximum equivalent length of pipe (m)		
	@ 8 l/m	@ 10 l/m	@ 18 l/m
2.0	33	13	5
2.5	110	45	17
3.0	200	80	30

Table 2 : Maximum equivalent pipe lengths in plastic pipe

Inlet pressure (bar)	Maximum equivalent length of pipe (m)		
	@ 8 l/m	@ 10 l/m	@ 18 l/m
2.0	10mm: 2.0	10mm: 1.3 15mm: 12.5	15mm: 4.5 22mm: 40
2.5	10mm: 4.0	10mm: 2.6 15mm: 25.0	15mm: 9.0 22mm: 80.0
3.0	10mm: 6.0	10mm: 3.9 15mm: 37.5	15mm: 13.5 22mm: 120

APPENDIX B

The size of the distribution pipes supplying the manifold should be calculated using the method set out in BS 6700. A typical diagrammatic arrangement of a system using Manifold Type 1 is shown below. This is only meant to show the principles involved and the actual connection of fittings to the manifold will need to suit the arrangements shown on page 35.

Note 1 - If it is proposed to fit chemical water treatment such as a water softener this should be fitted in this location and the cold water branch in the sink should be branched off the cold water main prior to the treatment device instead of the cold water manifold.

Any other isolating/control valves and backflow protection devices should be provided as necessary to comply with the Water Regulations.

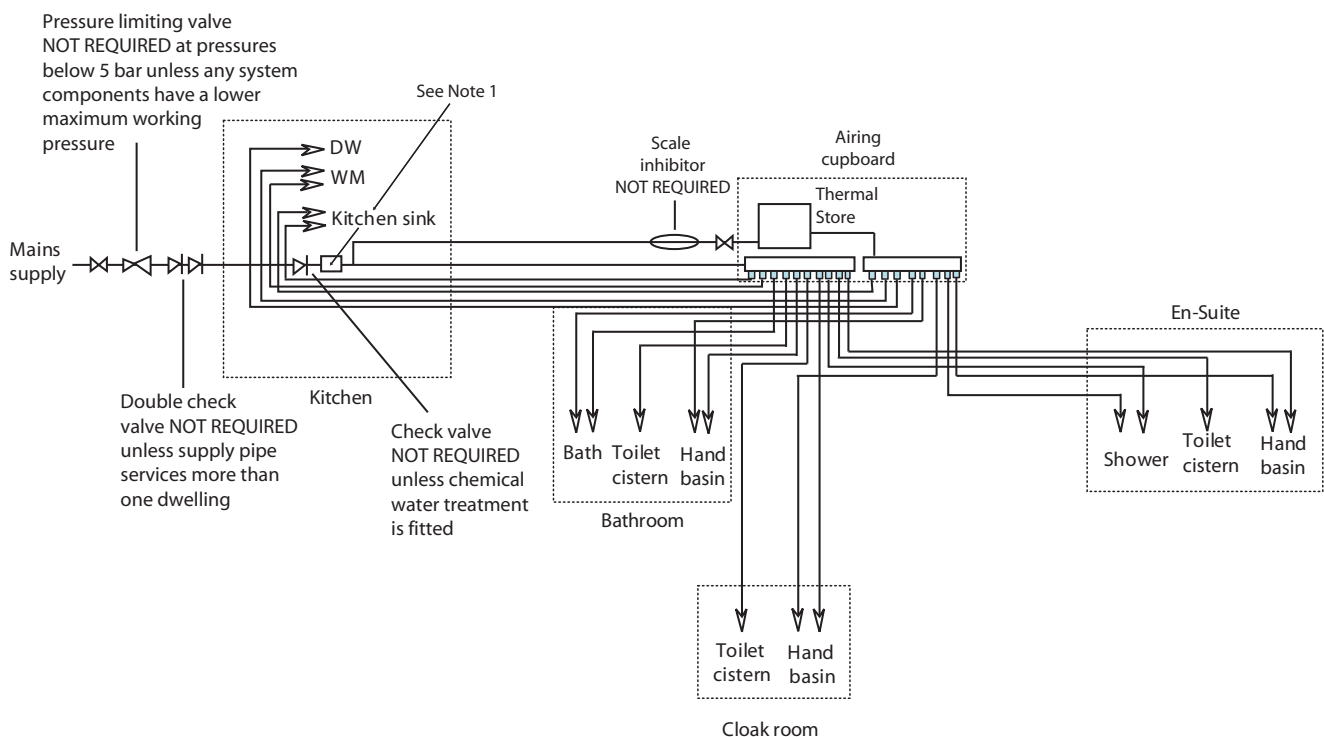



2 Inhibitor (Corrosion & scale protection of primary heating circuit)

On filling the heating system and before the boiler is fired up, it is important to ensure the system water is treated with a suitable corrosion inhibitor, in accordance with the boiler manufacturer's instructions.

Since the concentration of inhibitor present in a system can become diluted, for a number of different reasons, the system should be checked annually and re-treated as required, or after every full or partial drain-down. A water treatment manufacturer's test kit may be used to check the correct concentration of inhibitor in the system.

Where recommended by a boiler manufacturer, a 'physical corrosion protection device' may be fitted in the primary pipework in accordance with the boiler manufacturer's instructions.

The Benchmark log book should be completed indicating the date and details of any of the above products added and a permanent label should be fixed to the system in a prominent location.



3 Scale protection (Domestic hot water service)

Where a combi boiler and/or a hot water storage vessel is installed in areas where the mains water can exceed 200ppm Total Hardness (as defined by BS 7593: 1993 Table 2) a scale reduction device should be installed, in accordance with the boiler manufacturer's instructions.

The levels of water hardness may be measured using a water hardness test kit.

BUILDING REGULATIONS

Completion of the BENCHMARK log book requires that the 'competent person' undertaking the installation and commissioning provide information relating to Cleaning, Inhibitor and Scale Protection. This will demonstrate that the work complies with the requirements of the appropriate Building Regulations.

This Guidance Note is produced on behalf of its members by the Central Heating Information Council. For a full list of members visit www.centralheating.co.uk and for further advice on water treatment contact the following members:

 **Culligan**  **Sentinel**  **Fernox**  **Salamander Engineering**  **Scalemaster**

Heating & Hotwater Information Council, 36 Holly Walk, Leamington Spa,
Warwickshire CV32 4LY Tel: 0845 600 2200 Fax: 01926 423284
www.centralheating.co.uk



Benchmark is managed by The Heating & Hotwater Information Council

MANUAL HANDLING OF APPLIANCE PRODUCTS

Description

Manual handling means any transporting or supporting of a load (including lifting, putting down, pushing, pulling, carrying or moving) by hand or bodily force.

Scope

This assessment will cover the largest Appliance, namely ElectraMate, GulfStream, BoilerMate, Systemate, PulsaCoil and Accolade Manufactured by Gledhill Water Storage Ltd.

The maximum weight of the largest product in each range is 98kg and the size is 595 x 595 x 1900 mm high.

Main Hazards

Vision may not be clear due to the size of the products. Adopting an incorrect method of lifting may cause injury, attempting to lift these products will require help from others. (Team lifts)

Control Measures

Manual lifting procedure

The lift, key factors in safe lifting are:

- a. **Balance**
 - b. **Position of back**
 - c. **Positioning of the arms and body**
 - d. **The hold**
 - e. **Taking the lead for team lifts**
- a. **Balance** - Since balance depends essentially upon the position of the feet, they should be apart about hip breadth with one foot advanced giving full balance sideways and forward without tension. In taking up this position, lifting is done by bending at the knees instead of the hips and the muscles that are brought into use are those of the thigh and not the back.
 - b. **Position of back** - Straight - not necessary vertical. The spine must be kept rigid, this coupled with a bent knee position, allows the centre line of gravity of the body to be over the weight so reducing strain.
 - c. **Positioning of arms and body** - The further arms are away from the side, the greater the strain on the shoulders, chest and back. Keep elbows close to the body arms should be straight.
 - d. **The hold** - Before lifting ensure you have a good hold. Two handles are provided on Appliance products at the top rear side, these allow one or two persons to have a purposely-designed hold at the top of the appliance to ensure easy lifting at the top of the product. Each appliance is supplied with a pallet, which has been attached to the unit via the packaging. The pallet will also allow for one or two persons to get a good hold.

- e. **Taking the lead for team lifts**- As more than one person is required for these products ensure that one person is taking the lead. **This may be you** so ensure that each person that is helping is made aware of the weight and of the items listed within this assessment. Make sure you and any others helping know the route you intend to take that it is clear of any obstructions. Never jerk the load as this will add a little extra force and can cause severe strain to the arms, back and shoulders. If there are steps involved decide on where you will stop and take a rest period. Move smoothly and in unison taking care to look and listen to others helping with the lift. Where possible use a sack truck to move the product over long flat distances, only lift the products when necessary. If in doubt stop and get more help. The unit handles and packaging with the pallet have been designed to ensure that two-four people can assist when lifting up stairs or over longer distance.

Individual capability

Individual capability plays an important part in handling these products. Persons above average build and strength will find it easier and should be in good health. Persons below average build and strength may require more rest periods during the handling process. Pregnant women should not carry out this operation. Persons who are not in good health should seek medical advice prior to commencing any lifting or manual handling operation.

Residual risk

Following the guidelines given above will reduce any risk to injury. All persons carrying out this operation must be fully trained and copies of the specific risk assessment made available for inspection and use in their training process.

Further guidance on Manual Handling can be obtained from the Health and Safety Executive. Manual Handling Operations Regulations 1992.



CONDITIONS OF SALE & WARRANTY TERMS

1. We only do business upon the Conditions which appear below and no other. Unless we so agree in writing these Conditions shall apply in full to any supply of goods by us to the exclusion of any Conditions or terms sought to be imposed by any purchaser. These Conditions of Sale and Warranty Terms override those which are contained on the Invoice Forms and all Sales are now subject to these Conditions of Sale and Warranty terms only.

2. PRICE

Orders are accepted at the price ruling at the date of receipt of order; this price is our last published list price plus a supplement to allow for any increase in the price of copper between the dates of publication of our price lists ("the copper price supplement"). An order may not be cancelled or varied after acceptance without the written consent of the company. Such cancellation or variation shall be subject to such reasonable charges as may be appropriate.

3. SPECIFICATION

The goods are supplied in accordance with the Specifications (if any) submitted to the Purchaser and any additions and alterations shall be the subject of an extra charge. Any goods not so specified shall be in accordance with our printed literature or the literature of any of our component suppliers (subject to any modifications made since publication). If we adopt any changes in construction or design of the goods, or in the specification printed in our literature, the Purchaser shall accept the goods so changed in fulfilment of the order.

4. PAYMENT

The invoice price of goods shall be payable within 30 days of despatch by us of our invoice for the goods or such longer time as may be stated by our quotation or invoice. If we receive payment in full on or before the due date we will allow an appropriate settlement discount except where we have quoted a special net price. If payment is not received in full on or before the due date we shall be entitled in addition to the invoice price to:

- (i) payment of a sum equal to any increase in the copper price supplement applicable to the particular goods sold between the date of receipt of order and the date of receipt of payment in full; and
- (ii) interest on any part of the invoice price unpaid after the due date at the rate of 3% per annum over the base rate for the time being of HSBC Bank plc.

5. TIME

We give estimates of delivery dates in good faith and time of delivery is not nor shall be made of the essence of any contract nor shall we be liable for any loss or damage occasioned by delay in delivery.

6. DELIVERY

We deliver free normally by our own vehicles within 25 miles of any of our manufacturing depots. Delivery to any place more than 25 miles from one of our manufacturing depots is subject to our quoted delivery charges. We reserve the right to make delivery of goods contained in one order by more than one consignment and at different times. Where a period is agreed for delivery and such period is not extended by our Agreement, the Purchaser shall take delivery within that period. If the Purchaser fails to take delivery, we shall be entitled at the Purchaser's risk and expense to store the goods at the Purchaser's premises or elsewhere and to demand payment as if they had been despatched. Off loading at point of delivery shall be the responsibility of and be undertaken by the Purchaser.

7. SHORTAGES OR DAMAGE

Goods must be inspected before signature of delivery note and any damage, shortage or discrepancy noted on the delivery note and the goods returned on the same vehicle. The buyer must also give us immediate written notice of the damage, shortage or discrepancy so that we may prompt investigation.

8. RETURN OF GOODS

Goods may not be returned to the Company except by prior written permission of an authorised officer of the Company and such return shall be subject to payment by the Purchaser of handling and re-stocking charges, transport and all other costs incurred by the Company.

9. COMPANY LIABILITY

All our goods are made of the best materials from reputable manufacturers and where stated are manufactured to the appropriate British Standard. Complaints must be given to us immediately, before any action is taken, as responsibility cannot be accepted if repairs or renewals are attempted on site without our written authority.

Defects caused by corrosion or scale deposits are not covered by this guarantee save as expressly provided in paragraph (4) of this Condition 9.

Where we agree to rectify any defect, we reserve the right to undertake the work on our own premises.

The following guarantee covers faulty materials and manufacture for the stated period, **provided that:-**

- The unit has been installed in accordance with our installation and service instructions and all relevant codes of practice and regulations in force at the time of installation.
- That all necessary inlet controls and safety valves have been fitted correctly.
- It has only been used for the storage of potable water supplied from the public mains.
- **Where appropriate the unit has been regularly maintained as detailed in the installation and service instructions.**

(1) Domestic and Commercial Open Vented Cylinders and Tanks.

If the copper cylinder or tank or any integral pipework proves to be defective either in materials or workmanship, we will either repair or supply replacement at our option with the closest substitute in the case of any obsolete product to any address in Great Britain.

- (a) free of all charge during the first year after delivery by us.
- (b) thereafter at a charge of one-tenth of the then current list price and any copper price supplement and delivery charge during the second year after delivery by us and increasing by a further one-tenth on the second and subsequent anniversary of delivery by us.

AND FURTHER we will meet the contractors/installers reasonable costs in removing and replacing any defective Open Vented Copper Cylinder or Tank with defective integral pipework as follows:

(i) in the case of vessels of less than 80 imperial gallons capacity up to a maximum of one-half of the extent of our liability in regard to the replacement product expressed in (1) (a) and (b) above

ii) in the case of vessels larger than 79 imperial gallons capacity up to a maximum of one-quarter of the extent of our liability in regard to the replacement product as expressed in paragraphs (1) (a) and (b) above.

(2) Domestic Mains Fed Products

If the copper storage vessel itself or any integral pipework as part of the storage vessel assembly proves to be defective either in materials or workmanship, we reserve the right to either repair or supply replacements or the closest possible substitute in the case of any obsolete product and will collect and deliver to any address in England, Wales and Scotland (excluding all Scottish Islands).

(a) free of all charge during the first year after delivery by us.

(b) thereafter at a charge of one-fifth of the then current list price or any copper price supplement and delivery charge during the second year after delivery by us increasing by a further one-fifth on the second and subsequent anniversary of delivery by us.

AND FURTHER we will meet the contractors/installers reasonable costs in removing and replacing any defective copper storage vessel or storage vessel with defective integral pipework from the Domestic Mains Pressure Range of products up to a maximum of one-third of the extent of our liability in regard to the replacement product expressed in (2) (a) and (b) above.

(3) Integrated Boiler and Storage Vessel Products and Stand Alone Boilers

In the case of the GulfStream range of products and the Gledhill boiler range of products, Gledhill guarantees the heat exchanger (boiler) for material and construction faults for two years and FURTHER we will meet the installer/contractors reasonable costs in removing and replacing any DEFECTIVE heat exchanger up to a MAXIMUM of one third of the extent of our liability in regard to the replacement product.

THE RESPONSIBILITY FOR THE EXECUTION OF THIS GUARANTEE LIES WITH THE INSTALLER.

The guarantee becomes null and void if the appliance is used incorrectly, or in the event of proven negligence or incorrectly implemented repairs **OR FAILURE TO CARRY OUT THE RECOMMENDED INSPECTION/MAINTENANCE.** The guarantee also becomes null and void if changes are made to the appliance without our knowledge, or if the serial number on the appliance is removed or made illegible.

The annual service must be carried out by a competent installer in accordance with the advice given by Gledhill and using Gledhill approved parts.

(4) Components of our products other than Storage Vessels and Integral Pipework.

We will either extend to the purchaser the same terms of warranty as we are given by the manufacturer of the component or if the manufacturer does not give any warranty, replace free of charge any component which becomes defective within twelve months after the date of the delivery by us and is returned to us at the purchaser's expense but we shall not meet the cost of removal or shipping or return of the component or any other cost charges or damages incurred by the purchaser.

If the appliance manufactured by Gledhill incorporates a factory fitted scale inhibitor then during the period of three years from the date of delivery Gledhill will replace, free of charge, any plate heat exchanger fitted in the appliance as original equipment in which scale formation occurs that materially reduces the effectiveness of the plate heat exchanger. This guarantee does not extend to any other component installed within the Gledhill appliance or elsewhere in the Purchaser's domestic water system.

(5) General

In the case of goods manufactured solely in accordance with our specification and designs and in respect of any installation work carried out by or on our behalf, our entire liability and the purchaser's sole remedies (subject to (1-4) above) and shall be as follows:

(a) we accept liability for death or personal injury to the extent that it results from our negligence that of our employees agents or subcontractors.

(b) subject to paragraph (d) below, we accept liability for direct physical damage to tangible property to the extent that such damage is caused by our negligence that of our employees agents or subcontractors.

(c) our total liability to the purchaser over and above any liability to replace under (1 - 4) above (whether in contract or in tort including negligence) in respect of any one cause of loss or damage claimed to result from any breach of our obligations hereunder, shall be limited to actual money damages which shall not exceed £20,000 provided that such monetary limit shall not apply to any liability on the part of ourselves referred to in paragraph (a) above.

(d) except as provided in paragraph (a) above but otherwise notwithstanding any provision herein contained in no event shall we be liable for the following loss or damage howsoever caused and even if foreseeable by us or in our contemplation :-

(i) economic loss which shall include loss of profits, business revenue, goodwill or anticipated savings.

(ii) damages in respect of special indirect or consequential loss or damage (other than death, personal injury and damage to tangible property).

(iii) any claim made against the purchaser by any other party (save as expressly provided in paragraph (b) above).

(e) except in respect of our liability referred to in paragraph (a) above no claim may be made or action brought (whether in contract or in tort including negligence) by the purchaser in respect of any goods supplied by us more than one year after the date of the invoice for the relevant goods.

(f) nothing in these Conditions shall confer on the purchaser any rights or remedies to which the purchaser would not otherwise be legally entitled.

(6) Notwithstanding any other provision contained herein the Purchaser's hereby agree to fully indemnify us against any damages losses costs claims or expenses incurred by us in respect of any claim brought against us by any third party for :-

(a) any loss injury or damage wholly or partly caused by any goods supplied by us or their use.

(b) any loss injury or damage wholly or partly caused by the defective installation or sub-standard workmanship or materials used in the installation of any goods supplied by us.

(c) any loss injury or damage in any way connected with the performance of this contract.

PROVIDED that this paragraph (6) will not require the Purchaser to indemnify us against any liability for our own acts of negligence or those of our employees agents or sub-contractors.

FURTHER in the case of goods supplied by us which are re-sold to and installed by a third party by the Purchaser it will be the sole responsibility of the Purchaser to test the goods immediately after their installation to ensure that inter alia they are correctly installed and are in proper working order, and are not likely to cause any loss injury or damage to any person or property.

10. VARIATION OF WARRANTY AND EXCLUSION

Should our warranty and exclusion be unacceptable we are prepared to negotiate for variation in their terms but only on the basis of an increase in the price to allow for any additional liability or risk which may result from the variation.

Purchasers are advised to insure against any risk or liability which they may incur and which is not covered by our warranty.

11. RISK AND RETENTION OF TITLE

(a) goods supplied by us shall be at the Purchaser's risk immediately upon delivery to the Purchaser or into custody on the Purchaser's behalf or to the Purchaser's Order. The Purchaser shall effect adequate insurance of the goods against all risks to the full invoice value of the goods, such insurance to be effective from the time of delivery until property in the goods shall pass to the Purchaser as hereinafter provided.

(b) property in the goods supplied hereunder will pass to the Purchaser when full payment has been made by the Purchaser to us for :-

(i) the goods of the subject of this contract.

(ii) all other goods the subject to of any other contract between the Purchaser and us which, at the time of payment of the full price of the goods sold under this contract, have been delivered to the Purchaser but not paid for in full.

(c) until property in the goods supplied hereunder passes to the Purchaser in accordance with paragraph (2) above.

(i) the Purchaser shall hold the goods in a fiduciary capacity for us and shall store the same separately from any other goods in the Purchaser's possession and in a manner which enables them to be identified as our goods.

(ii) the Purchaser shall immediately return the goods to us should our authorised representative so request. All the necessary incidents associated with a fiduciary relationship shall apply.

(d) the Purchaser's right to possess the goods shall cease forthwith upon the happening of any of the following events, namely :-

(i) if the Purchaser fails to make payment in full for the goods within the time stipulated in clause 4 hereof.

(ii) if the Purchaser, not being a company, commits any act of bankruptcy, makes a proposal to his or her creditors for a compromise or does anything which would entitle a petition for a Bankruptcy Order to be presented.

(iii) if the Purchaser, being a company, does anything or fails to do anything which would entitle an administrator or an administrative receiver or a receiver to take possession of any assets or which would entitle any person to present a petition for winding up or to apply for an administration order.

(e) the Purchaser hereby grants to us an irrevocable licence to enter at any time any vehicle or premises owned or occupied by the Purchaser or in the possession of the Purchaser for the purposes of repossessing and recovering any such goods the property in which has remained in us under paragraph (2) above. We shall not be responsible for and the Purchaser will indemnify us against liability in respect of damage caused to any vehicle or premises in such repossession and removal being damaged which it was not reasonably practicable to avoid.

(f) notwithstanding paragraph (3) hereof and subject to paragraph (7) hereof, the Purchaser shall be permitted to sell the goods to third parties in the normal course of business. In this respect the Purchaser shall act in the capacity of our commission agent and the proceeds of such sale :-

(i) shall be held in trust for us in a manner which enables such proceeds to be identified as such, and :

(ii) shall not be mixed with other monies nor paid into an overdrawn bank account.

We, as principal, shall remunerate the Purchaser as commission agent a commission depending upon the surplus which the Purchaser can obtain over and above the sum, stipulated in this contract of supply which will satisfy us.

(g) in the event that the Purchaser shall sell any of the goods pursuant to clause (6) hereof, the Purchaser shall forthwith inform us in writing of such sale and of the identity and address of the third party to whom the goods have been sold.

(h) if, before property in the goods passes to the Purchaser under paragraph (2) above the goods are or become affixed to any land or building owned by the Purchaser it is hereby agreed and declared that such affixation shall not have the effect of passing property in the goods to the Purchaser. Furthermore if, before property in the goods shall pass to the Purchaser under paragraph (2) hereof, the goods are or become affixed to any land or building (whether or not owned by the Purchaser), the Purchaser shall:-

(i) ensure that the goods are capable of being removed without material injury to such land or building.

(ii) take all necessary steps to prevent title to the goods from passing to the landlord of such land or building.

(iii) forthwith inform us in writing of such affixation and of the address of the land or building concerned.

The Purchaser warrants to repair and make good any damage caused by the affixation of the goods to or their removal from any land or building and to indemnify us against all loss damage or liability we may incur or sustain as a result of affixation or removal.

(i) in the event that, before property in the goods has passed to the Purchaser under paragraph (2) hereof, the goods or any of them are lost, stolen, damaged or destroyed :-

(i) the Purchaser shall forthwith inform us in writing of the fact and circumstances of such loss, theft, damage or destruction.

(ii) the Purchaser shall assign to us the benefit of any insurance claim in respect of the goods so lost, stolen, damaged or destroyed.

12. NON-PAYMENT

If the Purchaser shall fail to make full payment for the goods supplied hereunder within the time stipulated in clause 4 hereof or be in default of payment for any other reason then, without prejudice to any of our other rights hereunder, we shall be entitled to stop all deliveries of goods and materials to the Purchaser, including deliveries or further deliveries of goods under this contract. In addition we shall be entitled to terminate all outstanding orders.

13. RISK

All goods sold by us shall be at the sole risk of the Purchaser from the date of despatch by us of the invoice for their price.

14. VALUE ADDED TAX

All prices quoted are exclusive of Value Added Tax which will be charged at the rate ruling at the date of despatch of invoice.

15. TRADE SALES ONLY

We are only prepared to deal with those who are not consumers within the terms of the Unfair Contract Terms Act 1977, the Sale of Goods Act 1979 and the Supply of Goods and Services Act 1982. Accordingly any person who purchases from us shall be deemed to have represented that he is not a consumer by so purchasing.

16. JURISDICTION

The agreement is subject to English/Scottish law and any dispute arising hereunder shall be settled in accordance therewith dependent upon the location.

